



Main instrument with measuring table



100 x 50 mm



Ball-bearing measuring table. Moves freely or over the threaded spindle with quick action drive. Workpiece attachment with two M8 threads. Max. perm. load: 5 kg. Optics holder with adjustable height by means of the wide knurled collars mounted on each side.



Opto-electronic measuring system with incremental steel scale



0,001 mm



Valid for one coordinate direction and working temperature range: $10 \mu\text{m} + 0,04 \cdot L \mu\text{m}$ (L in mm)

Optics



Upright, laterally correct image



30x



Monocular eyepiece with dioptic compensation. Rotating graticule. Built-in device for angle measurement: angle scale value 1° , readout $12'$ (assessment) Objective 2:1. Objectfield diameter 6,5 mm. Numerical aperture 0,05. Free working distance 100 mm (see drawing) Integrated transmitted light and oblique incident light with continuous brightness setting, 5 W each

Continued next page

ETALON TCM 50

Provides simplicity and user comfort – 100 x 50 mm measuring span – Numerical interval to 0,001 mm or 0.0001 in – High-precision – Built-in transmitted light and oblique incident light – Eyepiece with angle device – RS 232 digital output – In-house calibration certificate.



06839000 ETALON TCM 50 measuring microscope

Consisting of the following components::

- 1 TCM 50 measuring microscope, complete Measuring table (100 x 50 mm measuring span) with opto-electronic system and cable for the transmission of the measurement signal. Height adjustable optics holder. Monocular viewing tube. Objective for 30x magnification. Eyepiece with angle device. Built-in transmitted light and oblique incident light with continuous brightness setting.
- 1 A 50 Computing counter Up/down counter with a two-line numerical display (X and Y, 7-decade display). Numerical interval 0,001 or 0.0001 in. RS 232 digital output.

Supplied with:

- 1 Mains adapter, 100 to 240 Vac, 47 to 63 Hz, 11 to 13 Vdc, 30 W
- 1 Dust cover

Optional Accessories

- 06869027** Set of clamping components (listed individually on page P-37).







ETALON TCM 50









The measuring microscope with good value for money.



A 50 counter

-  Two-line LC display (coordinates X/Y) 7 decades and 7 segments per sign
-  0,001 mm or 0.0001 in
-  9 mm
-  Keyboard protected against oil and water splashing
-  RS 232

General

-  Main part with counter: mains adapter 100 to 240 V, 47 to 63 Hz, 11 to 13 Vdc, max. 30 W
-  0 °C to 50 °C
-  20 ± 0,5 °C
-  -20 °C to 70 °C
-  IP52 (counter) (IEC 60529)
-  EN 50081-1, EN 50082-2, EN 61000-3-2, EN 61000-3-3
-  8,2 kg (microscope) 0,5 kg (counter)
-  Shipping packaging
-  Identification number
-  In-house calibration certificate
-  Declaration of conformity

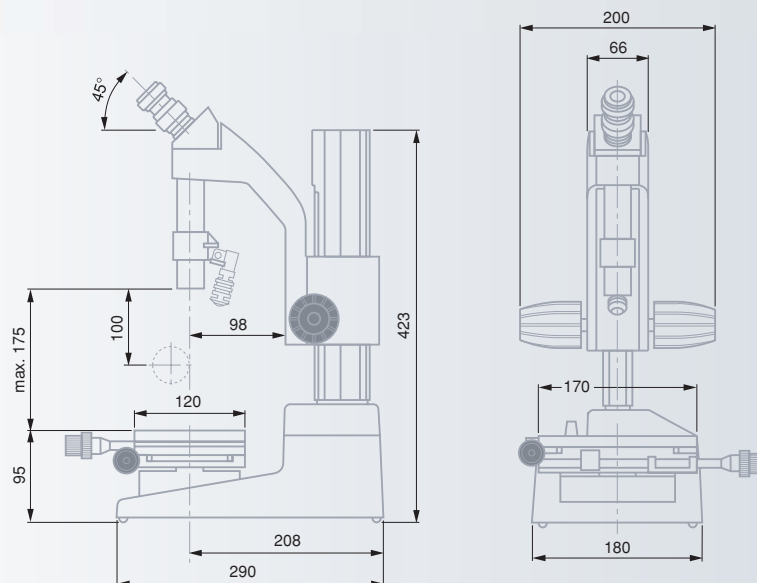



Main instrument with measuring table



100 x 50 mm



Ball-bearing measuring table.

Free move or fine displacement over the threaded spindle.

2 T-slots for tightening the workpiece.

Max. perm. load: 10 kg

Height adjustable optics holder by means of both fast and fine feed knobs



Opto-electronic measuring system with incremental steel scale



0,0005 mm



Valid for one coordinate direction as well as working temperature range: $2 \mu\text{m} + 0,02 \cdot L \mu\text{m}$ (L in mm)

Optics



Upright laterally correct image

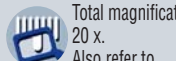

Total magnification: 20 x.

Also refer to optional accessories (objectives)

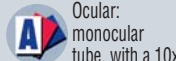

Ocular: monocular tube, with a 10x magnification, dioptic compensation and built-in graticule.

Objective with bayonet mount.

Interchangeable telecentric objectives 2:1 Object field diameter 10 mm.

Numerical aperture 0,06.

Free working distance 85 mm (see drawing).

Built-in transmitted and coaxial reflected light with continuous brightness setting, 20 W each

Continued next page

ETALON TCM 100

Most accurate and versatile – Ball-bearing measuring table with 100 x 50 mm measuring span – 0,0005 mm or 0.00002 in interval – High-precision with measurement errors contained within 6 μm over a 100 mm measured length – Superb optics with telecentric beam path providing excellent image quality with magnifications up to 1000x – Transmitted and coaxial reflected light – Video adapter – RS 232 digital output – In-house calibration certificate.



ETALON TCM 100



06819001



ETALON TCM 100 measuring microscope, without computing counter

Consisting of the following components:

- 1 Main instrument
Vertical column with height adjustable optics holder. Built-in transmitted and coaxial reflected light illumination with continuous brightness setting. 120 to 230 Vac, 50 to 60 Hz
- 1 Measuring table
Measuring span 100 x 50 mm. With opto-electronic measuring system and cable for the signal transmission as well as fast and fine displacement.
- 1 Ocular
Eyepiece with cup, 10x magnification. Monocular viewing tube with built-in graticule.
- 1 Measuring objective 2:1
Free working distance $a = 85 \text{ mm}$

Supplied with:

- 1 Dust cover





QUADRA-CHEK 120

Up/down computing counter with numerical display for both coordinate directions X and Y.

- Numerical interval to 0,0005 mm or 0.00002 in.
- Metric and inch units.
- Selectable languages: English, German, French, Italian and Spanish.
- Measurements performed with either a fixed or freely assignable origin point of coordinates.
- Reverse counting sense. Switchable.
- RS 232 digital output.

QUADRA-CHEK 220

Up/down computing counter having a microprocessor on board. Also with digital display for both coordinate directions X and Y as well as auxiliary display for the functions.

- No manual calculation.
- Metric and inch units.
- Selectable languages: English, German, French, Italian and Spanish.
- No mechanical workpiece alignment owing to the numerical translation of coordinates.
- Assignable number of points as large as 3 to 50 for inspecting diameters on pitch circles.
- Cartesian and polar coordinate systems.
- Possible combination of up to 50 measured values per geometric element.
- Location of origin points at the user's choice.
- PRESET function.
- Programmable measurement cycles (max. 250 steps).
- RS 232 digital output, bidirectional.
- Serial port for result output structured in any other format up to A4 format.

Programmed Measuring Functions



Point



Straight line



Circle



Distance



Angle



Alignment

Geometric Combination of the Measured Values (Examples)

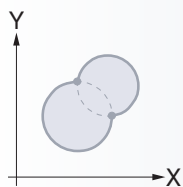

Insertion point of two straight lines

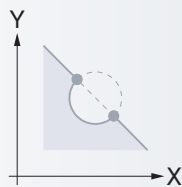

Insertion points of straight line/circle

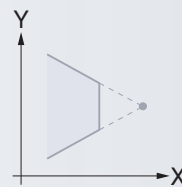

Insertion point of two straight lines

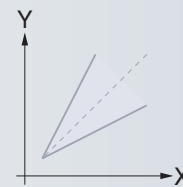

Angle median of two straight lines

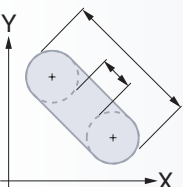

Circle distances

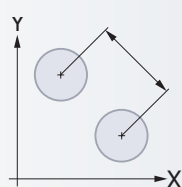

Centre-to-centre distances

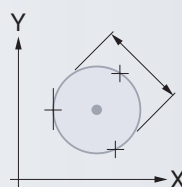

Bore diameters

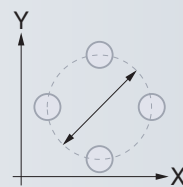

Diameters on pitch circles

General – Microscopes

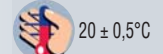

QUADRA-CHEK 120 and 220 Computing Counters

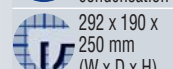
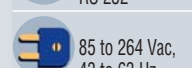
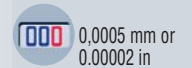



Optional Accessories



06869007 Rotary table
230 x 160 mm Surface area. Also with 2 T-slots.
Rotation range $\pm 7,5^\circ$

06869001 Oblique incident light for 230 V

Consisting of:

06869002 1 Light unit
Suitable for all objectives. Dual-arm fibre optic cable. Support rotating through to $\pm 45^\circ$ in the viewing axis.

06869003 1 CLS 100 cold light source
230 Vac, 50 to 60 Hz, 14,5 V, 90 W

On request 1 Reflective halogen lamp for CLS 100,
14,5 V, 90 W

06869005 Oblique incident light for 120 V

Same as above, but with the following feature also included:

On request 1 CLS 100 light source
120 Vac, 50 to 60 Hz, 90 W

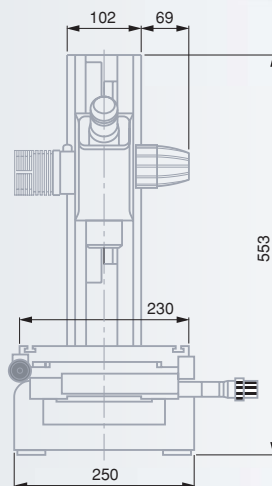
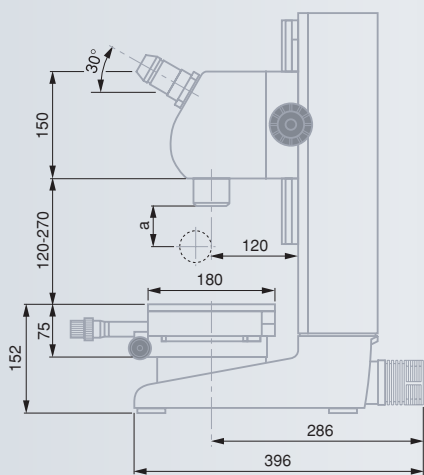

LEICA Plan Achromat measuring objectives (for further details, see page P-44)







	Objectives	Total magnification	Object-field	Numerical aperture	Free working distance a
06869008	1 : 1	10 x	20 mm	0,03	88 mm
06869009	5 : 1	50 x	4 mm	0,13	62 mm
06869010	10 : 1	100 x	2 mm	0,20	52 mm
06869011	20 : 1	200 x	1 mm	0,35	30 mm







LEICA Plan Fluor micro-objectives for metallographic examination

Convenient for both transmitted light and coaxial reflected light. Used with the single bayonet mount
No. 06869019

					
	Objectives	Total magnification	Object-field	Numerical aperture	Free working distance a
On request	2,5 : 1	25 x	8 mm	0,075	5,5 mm
On request	5 : 1	50 x	4 mm	0,10	10,5 mm
06869014	10 : 1	100 x	2 mm	0,20	10,5 mm
06869015	20 : 1	200 x	1 mm	0,40	10,5 mm
On request	40 : 1	400 x	0,5 mm	0,50	10,5 mm
06869017	50 : 1	500 x	0,4 mm	0,60	3,6 mm
06869018	100 : 1	1000 x	0,2 mm	0,70	3,6 mm



-  **06869019** **Single bayonet mount for micro-objectives**
Threads for micro-objectives from 2,5:1 to 100:1
-  **06869021** **C-mount adapter**
Allows the use of a video camera instead of the ocular
- 06869020** **KAPPA FK1/F electronic crossline graticule**
For use in conjunction with a video camera





Wooden case

Declaration of conformity



06869027

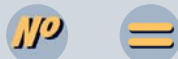

06869027 Set of clamping components

Suitable for ETALON microscopes TCM 50, TCM 100 and TCM 200

Consisting of:

06869028 1 SU articulated support

Dual-arm support with central clamp through the star grip. Total length 195 mm. With 1 socket joint and 2 ball joints. M8 fixing thread on the table side and 5 mm dia. fixing hole on the workpiece side. Max. perm. load: 400 g.

Clamp for attaching the SU support on the measuring table

2 T-slot blocks, type ETALON / LEICA
T-slot blocks with M8 fixing thread for articulation

06869029 1 Item, type V for vertical position.

06869030 1 Item, type H for horizontal position.

Workpiece oriented clamps for use with the SU support

With a 5 mm dia. fixing hole.

Spring clamp to hold workpieces down.

06869031 1 Item, 34 mm long.

06869032 1 Item, 50 mm long.

06869033 1 **P clamp for small parts**, max. clamp capacity. $\leq 1,8$ mm, resting width 3 mm, depth stop at 1,5 mm.

06869034 1 **M clamp for small parts**, max. clamp capacity. $\leq 5,0$ mm, resting width 4,8 mm, depth stop at 1,5 mm.

06869035 1 **Clamping chuck**, ≤ 3 mm in dia.

06869036 1 **Toggle clamp**, clamping capacity ≤ 25 mm.

06869037 1 **V-block with spring clamp**, covering the range from 2 to 25 mm. Vee angle 120°. Vee length 25 mm.

06869038 1 **Try-square**, beam length 120 x 80 mm. Includes 2 T-grooves for both columns No 06869039.

06869039 2 **Columns** used with the try-square for attaching the spring clamps listed below.

Spring clamp to hold the workpieces down.

06869040 1 Item, 34 mm long.

06869041 1 Item, 50 mm long.

Leaf spring clamp

to press the workpiece against the try-square.

06869042 1 Item, 34 mm long.

06869043 1 Item, 50 mm long.

06869044 1 **Adapter**, rotating through 4x90° with lock-in positions

1 Socket head key (2, 2,5 and 3 mm).

1 Clamping bolt for holes with a 5 mm dia.

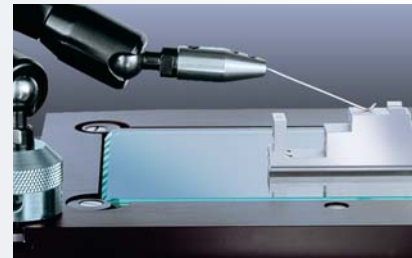
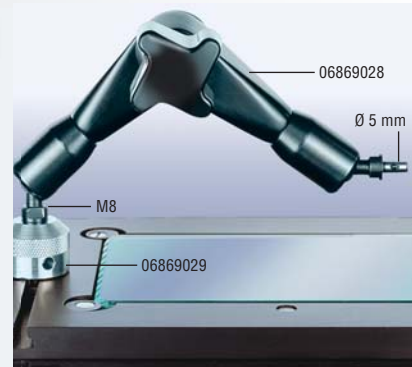

06869031



06869033



06869035



06869037



06869038/06869039/06869040/06869042



ETALON TCM 200

Modular concept – Custom built configurations for non-contact applications from length measurement through metallographic examination – Selectable telecentric objectives of superior quality – Optimum object illumination – Ball-bearing measuring tables having a 150 x 100 mm or 250 x 150 mm measuring span – Opto-electronic measuring systems with incremental steel scales – Computer based data processing – RS 232 digital output – In-house calibration certificate.

- Non-contact measurement in 1, 2 or 3 coordinate directions. No measuring force.
- Numerical interval to 0,0005 mm or 0.00002 in.
- High accuracy through very low permissible error, e.g. 2,6 µm only over a 150 mm measured length.
- High load capacity and long free working distances for the inspection of tall test pieces.
- Bright images for surface structure examination with magnifications up to 1000x.
- Video camera for image analysis.



Main instrument with measuring table



150 x 100 mm
250 x 150 mm



Main part in cast iron.

Optics holder guided on a ball-bearing, height adjustable using the feed knobs for fast and fine focusing, max. travel 150 mm. Steel ball-bearing measuring tables equipped with opto-electronic systems having incremental steel scales.



Valid in one coordinate direction as well as for either working temperature range of 1,8 µm + 0,005 · L µm for the 150 x 100 mm table or 2,5 µm + 0,01 · L µm (L in mm) for the 250 x 150 mm one.

Illumination



Coaxial reflected light and transmitted light with

knurled wheel used for setting the diaphragm aperture.

Light units with remote continuous brightness setting.

Fibre optic illumination.

Optical system



Binocular viewing tube with dioptic compensation for each eyepiece.

Eyepiece cups with 10x magnification.

20 mm dia. free opening, 25° viewing angle.

Upright, laterally correct image.

Interchangeable objectives and micro-objectives with bayonet mount.



General

10 °C to 40 °C

20 ± 0,5 °C

-10 °C to 60 °C

120 to 230 Vac
50 to 60 Hz

IP40
(IEC 60529)

EN 50081-1,
EN 50082-1,
EN 61000-4,
EN 61010-1

70 kg net
(main part
No. 06819010)

45 kg
(table 150 x 100)

70 kg
(table 250 x 150)

Setting key
and dust cover

Shipping
packaging

Identification
number

In-house
calibration
certificate

Declaration
of conformity

ETALON TCM 200 made ready-for-use – Ordering Variations

Equipped with binocular viewing tube for metrology oriented applications (for 230 V).
Additional technical data and ordering information as listed below.

No	Variant	Main part with binocular viewing tube	Cold light unit		Measuring table		Coordinate direction Z	QUADRA-CHEK		
			transmitted light 35 W	reflected light 90 W	Measuring span 150 x 100 mm	250 x 150 mm		220	230*	4000
06839006	1	●	●	●	●			●		
06839007	2	●	●	●		●			●	
06839008	3	●	●	●				●		
06839009	4	●	●	●		●				
06819006	5	●	●	●			●			○
06819007	6	●	●	●		●				○
06819008	7	●	●	●		●				○
06819009	8	●	●	●		●				○

* Execution for X, Y and Z coordinate directions: ETALON wit order No. 06839014.

○ Not included in the sales programme. Must be ordered locally.

Significant features

- Table freely moved by hand or finely displaced over the threaded spindle allowing quick positioning in each direction.
- Objectives with bayonet mount for easy exchange with just one hand.
- Inserts with crossline graticules and concentric circles.
- Patented angle device with digital measuring system (as pictured opposite)
- Centre support for use in conjunction with the insert fitted with both aperture diaphragm and interference slit used to check diameters on cylinders (as pictured opposite).
- Fibre optic illumination to eliminate all heat lighting.
- Image viewing in transmitted light, coaxial reflected light, oblique incident light and ring light as well as brightfield/darkfield. Also with or without polarised light or interference contrast (DIC).
- Dedicated compact counter for 2 and 3 coordinate directions.
- Software for value processing using a computer unit.

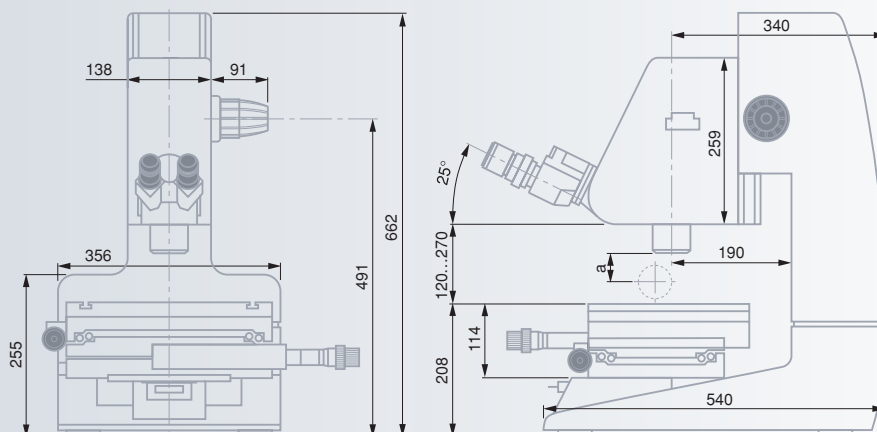

ETALON TCM 200 Key Components

TCM 200 Main Microscopes – Overview

Important: In order to let you work with your microscope efficiently, at least the following components must be added to all main instruments:

- Measuring table
- Cold light source for transmitted and reflected illumination
- Computing counter for value processing

№	=				
06819010		Main instrument with binocular viewing tube			●
06819011		Main instrument binocular viewing tube and measuring system (Z)			●
06819012		Main instrument video viewing tube		●	
06819013		Main instrument video viewing tube and measuring system (Z)	●		
<i>Consisting of:</i>					
		1 TCM 200 main body	●	●	●
		1 Optics holder with both mechanically operated fast and fine displacement	●	●	●
		1 Digital measuring system in the Z direction	●	●	
		1 Binocular viewing tube		●	●
		1 Video viewing tube	●	●	
		2 Eyepieces with a 10x magnification (order number for 1 item)		●	●
		1 Measuring objective 2:1	●	●	●
		1 Insert with aperture diaphragm	●	●	●



Components and Use of Accessories – General Overview

To be used with							●
	binocular viewing tube						●
	video viewing tube						●
	measuring system in the Z direction						●
	for length measurements						●
	surface examination						●
	in polarised light						●
	with interference contrast DIC						●
06869061	150 x 100 measuring table						●
06869062	250 x 150 measuring table						●
06869063	CLS 50 cold light source for transmitted light	12 V	35 W for 230 Vac				●
06869064			120 Vac				●
06869003	CLS 100 for reflected light and oblique incident light	14,5 V	90 W for 230 Vac				●
06869006			120 Vac				●
06869065	CLS 150 for reflected light and oblique incident light	15 V	150 W for 230 Vac				●
06869066			120 Vac				●
06869069	Insert with crosslines graticule					●	●
06869070	Insert with crosslines graticule and concentric circles					●	●
06869071	Angle device with measuring system (Q)					●	●
	LEICA Plan Achromat telecentric measuring objectives						
06869008	Objective	1:1	Total magnification	10x			●
06869009		5:1		50x			●
06869010		10:1		100x			●
06869011		20:1		200x			●
06869072	Centre support (for use with the 150 x 100 measuring table only)					●	●
06869073	Insert with aperture diaphragm and interference slit					●	●
06869002	Illumination unit with oblique incident light (objectives 1:1 to 10:1)					●	●
06869074	Illumination unit with ring light					●	●
06869075	Micro-optical head for 6 micro-objectives					●	●
06869076	Micro-optical head for 6 micro-objectives and polarised light					●	●
06869019	Single bayonet mount					●	●
	LEICA Plan Fluor micro-objectives for image viewing in polarised light (optional)						
06869012	Objective	2,5:1	Total magnification	25x		●	●
06869013		5:1		50x		●	●
06869014		10:1		100x		●	●
06869015		20:1		200x		●	●
06869016		40:1		400x		●	●
06869017		50:1		500x		●	●
06869018		100:1		1000x		●	●
06869077	Micro-optical head for 6 micro-objectives and image viewing in polarised light with interference contrast DIC					●	●
	LEICA Plan Fluor micro-objectives for image viewing in polarised light or not but with interference contrast DIC						
06869078	Objective	10:1	Total magnification	100x		●	●
06869079		20:1		200x		●	●
06869080		40:1		400x		●	●
06869081		50:1		500x		●	●
06869082		100:1		1000x		●	●
06839013	QUADRA-CHEK 220 for 2 coordinate directions (X and Y)						●
06839014	QUADRA-CHEK 230 for 3 coordinate directions (X, Y and Z)						●
06839015	QUADRA-CHEK 231 for 3 coordinate directions (X, Y and Z) plus angle (Q)						●
	QUADRA-CHEK 4000 software (available on request)						●
	Video system (available on request)					●	●
06869083	C-mount adapter with 1,2x magnification					●	●
06869084	C-mount adapter with built-in magnification changer (0,4x and 1,2x)					●	●
06869020	KAPPA FK1/F electronic graticule						●
06869027	Set of clamping components					●	●



Main Parts



No

=

06819010 Main part with binocular viewing tube for ETALON TCM 200
(measuring table and computing counter excluded)

Consisting of the following components:

- 1 TCM 200 main part in cast iron, varnished.
Vertical column with guide adjusted to the optics holder No. 06869086 (max. displacement 150 mm). Fibre optic transmitted light illumination.
- 1 Optics holder
With mechanically operated knurled collars for fast and fine focusing. Accommodates the attachment for the viewing tube.
- 1 Binocular viewing tube
Provided with dioptic compensation for each eyepiece, single bayonet mount for LEICA Plan Achromat and Plan Fluor objectives or the micro-optical head, ocular accommodated attachment, video camera adapter (C-mount) and angle device. Coaxial reflected illumination via fibre optic.
- 2 Eyepieces
With a 10x magnification plus cups (order number for 1 item only)
- 1 Measuring objective 2:1
Free working distance $a = 85$ mm
- 1 Insert with aperture diaphragm
For use in transmitted light.
With setting knurled wheel.

No

=

06819012 Main part with video viewing tube for ETALON TCM 200
(measuring table and computing counter excluded)

Consisting of the following components:

- 1 TCM 200 main part
Cast iron, varnished. Vertical column with guide adjusted to optics holder No. 06869086 (max. displacement 150 mm). Fibre optic transmitted illumination.
- 1 Optics holder
With mechanical fast and fine focusing. Accommodates the attachment for the viewing tube.
- 1 Video viewing tube
Provided with single bayonet mount for LEICA Plan Achromat and Plan Fluor objectives or the micro-optical head. Also with C-mount adapter Adapter (C-mount) for the video camera. Coaxial reflected illumination via fibre optic.
- 1 Objective 2:1
Free working distance $a = 85$ mm
- 1 Insert with aperture diaphragm
For use in transmitted light.
With setting knurled wheel.

No

=

06819011 Main part with binocular viewing tube plus digital measuring system in Z coordinate direction
(measuring table and computing counter excluded)

Identical to the model No. 06819010 described above, but with the following added option:

- 06869090** 1 Opto-electronic measuring system
Mounted in the coordinate direction Z with incremental steel scales, 0,0001 mm resolution.

No

=

06819013 Main part with video viewing tube plus digital measuring system in Z coordinate direction
(measuring table and computing counter excluded)

Identical to the model No. 06819012 described above, but with the following added option:

- 06869090** 1 Opto-electronic measuring system
Mounted in the coordinate direction Z with incremental steel scales, 0,0001 mm resolution.





Ball-bearing guiding. Free move or fine displacement over the threaded spindle. With 2 T-slots for tightening the workpiece. Max. load capacity 30 kg (table 150 x 100) 20 kg (table 250 x 150)

Opto-electronic system with incremental steel scale. TTL signal form.

0,0001 mm



Shipping packaging

Declaration of conformity

QUADRA-CHEK 200 Computing Counter



Black/white LC display

0,0005 mm or 0.00002 in

Parallel and RS 232

85 to 264 Vac, 43 to 63 Hz

EN 61326: 1998 EN 61010

0°C to 45°C

292 x 190 x 250 mm (W x D x H)

4,8 kg without cable

Shipping packaging

Declaration of conformity

Measuring Tables



06869061 150 x 100 measuring table
150 x 100 mm measuring span (X/Y axes). Rotary stage (320 x 240 mm surface area) rotatable through $\pm 5^\circ$ for manual workpiece alignment. With cable for transfer of the measurement signal.

06869062 250 x 150 measuring table
250 x 150 mm measuring span (X/Y directions). Surface area 420 x 256 mm. With cable for transfer of the measurement signal.

Note
Executions with motorised displacement in the two coordinate directions X and Y also available upon request.



Cold light sources



Cold light sources for transmitted illum. 35 W
Includes both a 12 V reflective halogen lamp (No. 06869067) and continuous brightness setting.

06869063 CLS 50 for 230 Vac, 50 to 60 Hz
06869064 CLS 50 for 120 Vac, 50 to 60 Hz

Cold light sources for reflected illum. 90 W
Includes a 14,5 V reflective halogen lamp (No. 06869004) and continuous brightness setting.

06869003 CLS 100 for 230 Vac, 50 to 60 Hz
06869006 CLS 100 for 120 Vac, 50 to 60 Hz



Systems for Value Processing



QUADRA-CHEK 200 Computing Counter
Up/down computing counter with alphanumerical LC display and colour background. Languages available: English, French, German, Italian and Spanish. Computerised workpiece alignment. Also with functions to calculate for geometric combinations, programmable measurement cycles, memory as well as parallel, digital RS 232 and infrared outputs.

06839013 QUADRA-CHEK 220
For 2 coordinate directions (X and Y)

06839014 QUADRA-CHEK 230
For 3 coordinate directions (X, Y and Z)

06839015 QUADRA-CHEK 231
For 3 coordinate directions (X, Y and Z) and Q (Angle device No. 06869071)





QUADRA-CHEK 4000 – Software programme for value processing

For value processing and output using a PC.

Permits the user to view the image through the binocular viewing tube or using a video camera linked to an additional viewing screen.

For QUADRA-CHEK 4000 running under WINDOWS, the option enabling automatic edge detection can also be provided for further image analysis.

The computing cards necessary for connecting the microscope to the computer can be quoted as follows:

- 1 Dual-input computing card for both X and Y coordinate directions
- 2 Dual-input computing cards for the three coordinate directions X, Y and Z
- 2 Dual-input computing cards for both X and Y coordinate directions as well as angle device (Q)
- 2 Dual-input computing cards for the three X, Y and Z coordinate directions as well as angle device (Q)

For a quotation, we recommend to get in touch with your local ACU-RITE dealer, directly.

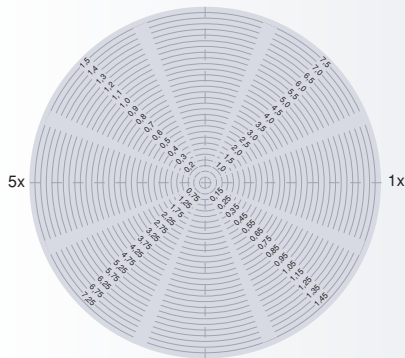

Accessories for Metrology Applications using TCM 200



06869069 Insert with crosslines graticule

90° crosslines graticule with 2 additional index lines to $\pm 60^\circ$. To be used in conjunction with the binocular viewing tube No. 06869087.

06869070 Insert with crosslines graticule and concentric circles

90° crosslines graticule with 2 additional index lines to $\pm 60^\circ$ as well as 2 sets of 30 concentric lines each.

Magnification	Diameter	Stepping
10x	0,25 ÷ 7,5 mm	0,25 mm
20x	0,25 ÷ 3,75 mm	0,125 mm
50x	0,05 ÷ 1,5 mm	0,05 mm
100x	0,05 ÷ 0,75 mm	0,025 mm

Usable with the binocular viewing tube No. 06869087

06869071 Insert with protractor and digital measuring system

Crossline graticule combined with opto-electronic measuring system, which is based on incremental scale divisions. Both features can be rotated.

Sinusoidal output signal $\pm 11 \mu\text{App}$. To be used with the binocular viewing tube No. 06869087

LEICA Plan Achromat objectives

High-quality telecentric measuring objectives producing a perfect erect image, thus allowing a definite and precise observation of the contours.

Long working distances, e.g. for the inspection of test pieces having awkward edges or for bore measurements.

Easily and quickly exchanged. Safely attached through the bayonet mount.



Shipping packaging



Declaration of conformity



Shipping packaging

Declaration of conformity

LEICA Plan Achromat Objectives



No.	Objectives	Highest magnification	Object-field	Numerical aperture	Free working distance a
06869008	1 : 1	10 x	20 mm	0,03	88 mm
06869022*	2 : 1	20 x	10 mm	0,06	85 mm
06869009	5 : 1	50 x	4 mm	0,13	62 mm
06869010	10 : 1	100 x	2 mm	0,20	52 mm
06869011	20 : 1	200 x	1 mm	0,35	30 mm

*Objective 2:1 is part of ETALON TCM 200



Shipping packaging

Declaration of conformity



06869072 Centre support

Serves to measure parts with symmetrical rotation. Max. width of points 190 mm. Max. diameter 50 mm. Usable solely with the 150 x 100 measuring table (No. 06869061). Supplied with a setting piece designed for inspecting diameters on cylinders according to the method that uses interference fringes. This support requires the use of the insert No. 06869073.

06869073 Insert with aperture diaphragm and interference slit

For diameter inspection on cylinders in transmitted light on the basis of the interference method. Used with the centre support No. 06869072. Includes a knurled wheel to set both the aperture diaphragm and interference contrast.

06869002 Oblique incident light unit

Suitable for measuring objectives 1:1 to 10:1. Dual-arm fibre optic cable with holder rotating through $\pm 45^\circ$ in the optical axis. For use in conjunction with the cold light unit CLS 100 (90 W, No. 06869003 or 06869006) or CLS 150 (150 W, No. 06869065 or 06869066).

06869074 Ring light unit

Suitable for all measuring objectives. Includes one fibre optic cable. For use with the CLS 100 cold light unit (90 W, No. 06869003 or 06869006)



Note

Mounting the measuring device for diameter inspection according to the interference method requires a specific knowledge. Therefore, allowances should be made for this feature at the date of purchase of your microscope. This device includes the centre support along with the insert as listed opposite.



Accessories for Surface Structure Examination



Nº

=

06869019 Single bayonet mount for micro-objectives

With threads for micro-objectives 2,5:1 to 100:1. For transmitted and coaxial reflected illumination.



Nº

=

06869075 Micro-optical head suited for 6 micro-objectives

Consisting of:

- 1 Main part
With changer for 6 LEICA Plan Fluor micro-objectives 2,5:1 to 100:1 and 1 fibre optic cable (light unit No. 06869003 or 06869006 not included).
- 1 Triple-module illumination
Mounted in the main body with coaxial reflected light (darkfield/brightfield).

06869076 Micro-optical head suited for 6 micro-objectives as well as image viewing in polarised light

Includes the same components as No. 06869075 above plus the following additional option:

- 1 Polariser
Mounted in the main part..



Micro-optical heads furnished in a carrier packing with aerated foam that can be inserted into a drawer for further use



Declaration of conformity

LEICA Plan Fluor micro-objectives for image viewing with or without polarised light

Convenient for illumination in transmitted and coaxial reflected light. To be used with the single bayonet mount No. 68.69019 or the micro-optical head No. 06869075 or 06869076, without interference contrast DIC.

Nº

=



Objectives

Total magnification

Object-field

Numerical aperture

Free working distance a

06869012	2,5 : 1	25 x	8 mm	0,075	5,5 mm
06869013	5 : 1	50 x	4 mm	0,10	10,5 mm
06869014	10 : 1	100 x	2 mm	0,20	10,5 mm
06869015	20 : 1	200 x	1 mm	0,40	10,5 mm
06869016	40 : 1	400 x	0,5 mm	0,50	10,5 mm
06869017	50 : 1	500 x	0,4 mm	0,60	3,6 mm
06869018	100 : 1	1000 x	0,2 mm	0,70	3,6 mm



Shipping packaging



Declaration of conformity





Micro-optical heads in a carrier packing with aerated foam that can be inserted in a drawer for further use



Declaration of conformity



06869077 Micro-optical head suited for 6 micro-objectives and image viewing in polarised light with interference contrast (DIC)

Consisting of the same components as No. 06869075, but provided with the following added options:

- 1 Polariser
Mounted in the main part.
- 1 DIC drawer.
With adjustable Wollaston prism.

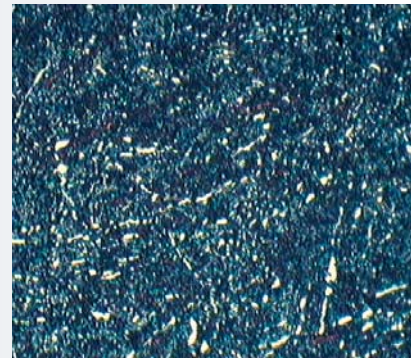

Shipping packaging



Declaration of conformity

LEICA Plan Fluor micro-objectives for image viewing with or without polarised light, with interference contrast DIC

Convenient for illumination in transmitted and coaxial reflected light. To be used with the single bayonet mount No. 06869019 or the micro-optical head No. 06869076 or 06869077. These objectives are marked with «IK» for «Interference contrast».



	Objectives	Total magnification	Object-field	Numerical aperture	Free working distance a
06869078	10 : 1	100 x	2 mm	0,20	10,5 mm
06869079	20 : 1	200 x	1 mm	0,40	10,5 mm
06869080	40 : 1	400 x	0,5 mm	0,50	10,5 mm
06869081	50 : 1	500 x	0,4 mm	0,60	3,6 mm
06869082	100 : 1	1000 x	0,2 mm	0,70	3,6 mm



Video Systems for ETALON TCM 200

Microscope with binocular viewing tube

All adapters listed hereafter allow the microscope to accommodate a video camera with C-mount.



Nº

=

06869083 C-mount adapter with a 1,2x magnification

consisting of:

- 1 Adapter with a 1,2x magnification factor
- 1 C-mount attachment for the camera

06869084 C-mount adapter with integrated magnification changer

consisting of:

- 1 Adapter with integrated magnification changer, magnification factors of 0,4x/1,2x. Convenient only for a 0.5 in camera.
- 1 C-mount attachment for the camera.



Shipping packaging



Declaration of conformity

Microscope with a video viewing tube

The electronic graticule shown below is intended for use with any QUADRA-CHEK 200 computing counter. However, this feature is unnecessary with QUADRA-CHEK 4000.



100 to 240 Vac
50 to 60 Hz



Connecting cable



Shipping packaging



Declaration of conformity

Nº

=

06869020 KAPPA FK1/F electronic crossline graticule

Connected to the video screen.

The graticule (white or black) overlaps the camera image.

Workpiece Attachments



Nº

=

06869027 Set of clamping components

For a safe positioning of the workpieces to be measured or parts to be examined. Equally suited for ETALON microscopes.

Single components as listed on page 37.



Wooden case



Declaration of conformity





Components with additives free from chlorine, fluorine or sulfur. Being non-toxic and non-polluting can be used with no special restriction



Polymerization will not occur below 10 °C

Shrinking: less than 1 µm/mm after removal of the mould
Stability: physical properties allow to produce prints which do not deteriorate with time. They will neither be affected by surroundings – hence usable as master standards.

PLASTIFORM

Non Destructive Control through Print Molding



The products «PLASTIFORM Soft» allow print molding of complex internal machined parts, which can then be viewed and checked using an optical, non-contact measuring equipment.

The products «PLASTIFORM with Additives» consist of two components, which have to be mixed in equal proportion to ensure a proper polymerization.

The test object to be reproduced by print molding must be perfectly clean as well as non-greasy before applying Pastiform.



06869100 Complete DS case

Provided with the following standard accessories:

- 1 DS50 injection handle
- 1 Cutter, special with two parallel blades
- 1 PLASTIN (200 g)
- 25 Mixer-Injectors, colour pink
- 25 Mixer-Injectors, colour turquoise
- 10 Injector end pieces
- 1 DN1 spot remover, 400 ml
- 21 Rings for mould removal
- 3 PLASTIFORM BAD S50
- 3 PLASTIFORM DAV S50
- 2 PLASTIFORM SOFT S50



Properties

	BAD ●	DAV ●	SOFT ●	JAD ●	KVAD ●
Two components	Blue+White	Green+White	Orange+White	Turquoise+White	Green+White
Consistence	Fluid	Fluid	Pasty	Pasty	Mastic
Colour	Blue	Green	Orange	Turquoise	Green
Smell	None	None	None	None	None
Polymeriz. time at 20 °C	8 minutes	8 minutes	8 minutes	8 minutes	8 minutes
SHORE A hardness	50/55	25/30	50/55	25/30	70/75
Elasticity	Elastic	Very elastic	Elastic	Very elastic	Hardly elastic
Density	1,3	1,3	1,3	1,3	1,6



BAD ●

Fluid consistency best suited for moulding internal and full prints of small and medium sizes. Medium elasticity (10% of the core) allows prints to be removed in most cases. Reproduces the finest details and can be used for indirect inspection of the surface finish by sight comparison with use of master roughness specimens. Easily cut with the special cutter.

DAV ●

Fluid consistency best suited for moulding internal and full prints of small and medium sizes. High elasticity (20% of the core) allows hard prints to be removed such as large re-entrant angle, groove, complex internal shape. Reproduces fine details. Uneasy to cut with a cutter. Print will be preferably checked as a whole..

SOFT ●

Pasty consistency best suited for moulding internal, external and sectorial prints of small and medium sizes. Medium elasticity (10% of the core) allows prints to be removed in most cases. Able to reproduce small details. Easily cut with the special cutter.

JAD ●

Pasty consistency best suited for moulding internal, external and sectorial prints of small and medium sizes. High elasticity (20% of the core) allows hard prints High elasticity (20% of the core) allows hard prints to be removed such as large re-entrant angle, groove, complex internal shape. Uneasy to cut with a cutter. Print will be preferably checked as a whole.

KVAD ●

Mastic consistency best suited for moulding internal, external and sectorial prints of small and medium sizes. Applied by hand. Low elasticity (from 1 to 2% of the core) makes it convenient for moulding prints that are removed with ease. Also appropriate for prints held mechanically if desired. Easily cut with the cutter.



Accessories

Nº

=

06869101	BAD PLASTIFORM S50, 8 double cartridges, 50 ml
06869102	DAV PLASTIFORM S50, 8 double cartridges, 50 ml
06869103	SOFT PLASTIFORM S50, 8 double cartridges, 50 ml
06869104	JAD PLASTIFORM S50, 8 double cartridges, 50 ml
06869105	KV-AD PLASTIFORM in packs of 2 boxes (A + B), 800 g each
06869106	Mixer-injectors in packs of 50, colour pink
06869107	Mixer-injectors in packs of 100, colour pink
06869108	Mixer-injectors in packs of 200, colour pink
06869109	Injector nozzles in packs of 20
06869110	PLASTIN (200 g). Malleable under normal conditions. Used to make «stops» or «retainers» when executing sectorial prints. Reusable.
06869111	Cutter, special with two parallel blades spaced 1 mm apart over a usable length of 60 mm.
06869112	DS 50 injection handle
06869113	DN1 spot remover, aerosol can, 400 ml
06869114	Mixer-injectors in packs of 50, colour turquoise
06869115	Mixer-injectors in packs for 100, colour turquoise
06869116	Mixer-injectors in packs of 200, colour turquoise