

MERCER Setting Standards

Air gauge applications using MERCER products require (at least) two setting standards.

- Supplied with a calibration certificate upon request.

MERCER Setting Rings for Air Plug Gauges

- Application ranges from 1,30 to 150,00 mm/0.051 to 5.90 in.

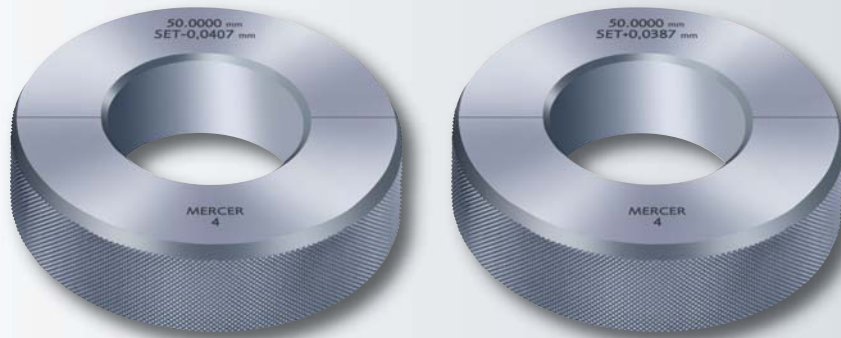

Steel, hardened to ≥ 59 HRC



Shipping packaging



UKAS calibration certificate on request

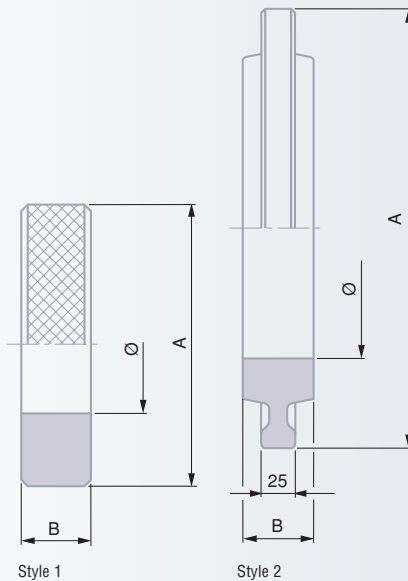

mm	A mm	B mm
$d_n \leq 6$	Ø 24	8
$6 \leq d_n \leq 12$	Ø 28	10
$12 \leq d_n \leq 18$	Ø 42	15
$18 \leq d_n \leq 24$	Ø 56	20
$24 \leq d_n \leq 32$	Ø 72	25
$32 \leq d_n \leq 42$	Ø 90	30
$42 \leq d_n \leq 52$	Ø 100	30
$52 \leq d_n \leq 62$	Ø 110	30
$62 \leq d_n \leq 74$	Ø 130	35
$74 \leq d_n \leq 86$	Ø 142	35
$86 \leq d_n \leq 100$	Ø 154	35
$100 \leq d_n \leq 120$	Ø 184	38*
$120 \leq d_n \leq 140$	Ø 210	38*

* Style 2

A mm	μm^*	μm^*	μm^{**}	μm	μm
$1,50 \leq d_n \leq 2,97$	1,0	2,5	0,5	0,5	0,5
$2,97 \leq d_n \leq 25,00$	1,0	2,5	0,5	0,5	0,5
$25,00 \leq d_n \leq 61,95$	1,0	2,5	0,75	1,0	0,75
$61,95 \leq d_n \leq 101,85$	2,0	5,0	1,0	1,5	1,0
$101,85 \leq d_n \leq 150,00$	2,0	5,0	1,5	2,0	1,25

* Max. perm. deviation of the mean value measured from the nominal size.
 ** Uncertainty against the actual size or actual deviation marked on the air ring.

Important
 When asking for a quotation or writing down your order, it is important to state your requirements according to the information on page O-6.

MERCER Setting Plugs Gauges for Air Ring Gauges

- Single or double ended plug gauges fitted with a hand grip according to their size.
- Maximum permissible error of 1 µm with respect to the nominal size or nominal deviation.



Important

When asking for a quotation or writing down your order, it is important to state your requirements according to the information on page O-6.



Additional Components

Extensions for deep holes

- Available for M type plug gauges with nominal diameters ranging from 14 to 62 mm/0.55 to 2.5 in.
- Increase depth by 25, 50, 75, 100 or 200 mm/1, 2, 3, 4 or 8 in.
- Air plug gauges with special design are also available for extra deep holes (nominal diameters up to 14 mm/0.55 in).



Depth Stop Rings for Air Plug Gauges

- Can be supplied with any air plug, except for the miniature versions.
- Other versions specially made to suit your gauging applications also available.



90° Adaptors

These adaptors are designed to help reaching the desired points during any machining operations while the work piece is still on the machine.

- Convenient for air plug gauge style S, M and L as well as for ring gauges.
- Universal handle for use in conjunction with both S and M type plugs or screw connected 200 mm long hand grip on L type adaptor.

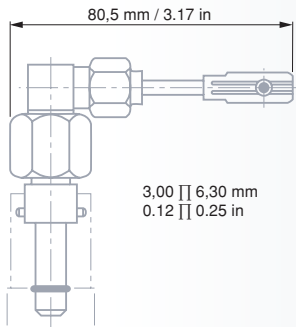
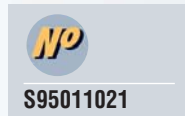

Style S

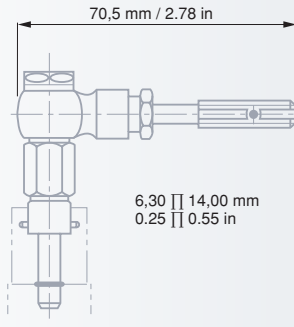

Style M

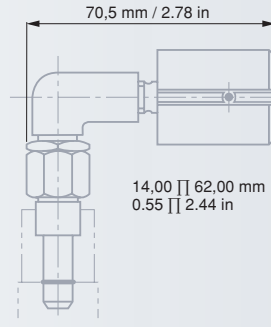

Style M

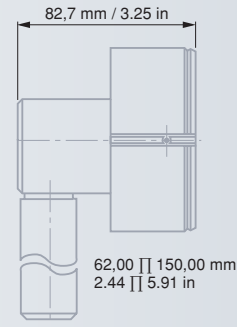

Style L

Universal Adaptor Handle

- Equally suited for air plugs and air rings with bayonet fittings.
- Supplied with 1,3 m long flexible hose for coupling with the gauging unit.

Base for stationary use

- Equally suited for air plugs and air rings.
- Screw connected hose end, air plugs and air rings.

