

Main Part



Heavy duty all steel structure



Measuring system with incremental glass scale, opto-electronic. Resolution 0,001 mm.



Optics precision  $\pm 0,05\%$  (profile illumination);  $\pm 0,10\%$  (surface illumination).



Resolution 0,001 mm



Profile illumination: 24 V / 150 W bulb. Also with thermal filter included. Surface illumination: adjustable fibre optic, 24 V / 200 W bulb. Also with thermal filter included.



10°C to 40°C



19°C to 21°C



80%, non-condensing



115 to 230 Vac  $\pm 10\%$ ; 50 to 60 Hz



110 kg



IP40



IEC 61010  
EN 60204  
EN 61326-1



Serial number



TESA calibration certificate



Declaration of conformity



Provided fully mounted, but without objective (must be ordered separately)



Shipping packaging

## TESA-SCOPE II 300V or 300V Plus

Perfect for checking parts with flat surfaces or any other component used in precision mechanics.



- Profile projectors with vertical illumination.
  - 360° rotary viewing screen in frosted glass, 300 mm diameter. 30°, 60° or 90° crossline reticle along with 4 overlay chart clips.
  - Screen rotation with built-in sexagesimal and decimal reading, resolution in minutes – RAZ ABS/INC.
  - Profile illumination with green filter included. Enhances image contrast, makes the measurement easier, reduces all effects due to the operator.
  - Surface illumination through adjustable fibre optic for a perfect image projection.
  - Save Lamp system for automatic shut down of the lamps whenever the projector remains unused for several minutes (thus increasing the life of the lamps by 5).
  - Objectives with bayonet mount for quick exchange.
  - Coordinate table equipped with incremental glass scales, opto-electronic. Resolution to 0,001 mm.
- Measuring span:
- 200 x 100 for standard model
  - 300 x 150 for model **Plus**
  - X-axis fitted with a clutch mechanism for fast displacement.
  - Control handle for left hand and right hand operator (X-axis motion).
  - Workload capacity up to 10 kg.
- Lateral paper sheet holder.



	Base	Measuring Table		Digital Readout / Control Panel		
		X=200 mm Y=100 mm	X=300 mm Y=150 mm	TS100	TS300	TS300E
TESA-Scope II 300V	06830041	●	●	●		
TESA-Scope II 300V	06830042	●	●		●	
TESA-Scope II 300V	06830043	●	●			●
TESA-Scope II 300V Plus	06830044	●		●		
TESA-Scope II 300V Plus	06830045	●			●	
TESA-Scope II 300V Plus	06830046	●				●

### Small Table

- Anodized aluminium
- Table surface  
350 x 210 mm (X/Y)
- Measuring span:  
200 x 100 mm (X/Y)
- In one coordinate direction:  
(4,5 + L/40) µm  
≤ 8 µm (L in mm)
- Max. workload capacity  
10 kg

### Telecentric Objectives

	10x	20x	25x	31,25x	50x	100x
	06860001	06860002	06860003	06860004	06860005	06860006
Object-field	30 mm	15 mm	12 mm	9,6 mm	6 mm	3 mm
working distance (W)	80 mm	82 mm	70 mm	56 mm	53 mm	43 mm
Maximum height (H)	83 mm	83 mm	83 mm	83 mm	83 mm	83 mm
Maximum Diameter (D)	166 mm	166 mm	166 mm	166 mm	166 mm	166 mm
Objective length (C)	37 mm	35 mm	47 mm	61 mm	64 mm	74 mm

### Large Table

- Anodized aluminium
- Table surface  
440 x 282 mm (X/Y)
- Measuring span:  
300 x 150 mm (X/Y)
- In one coordinate direction:  
± 5,0 + L/20 (L in mm)
- Max. workload capacity  
10 kg

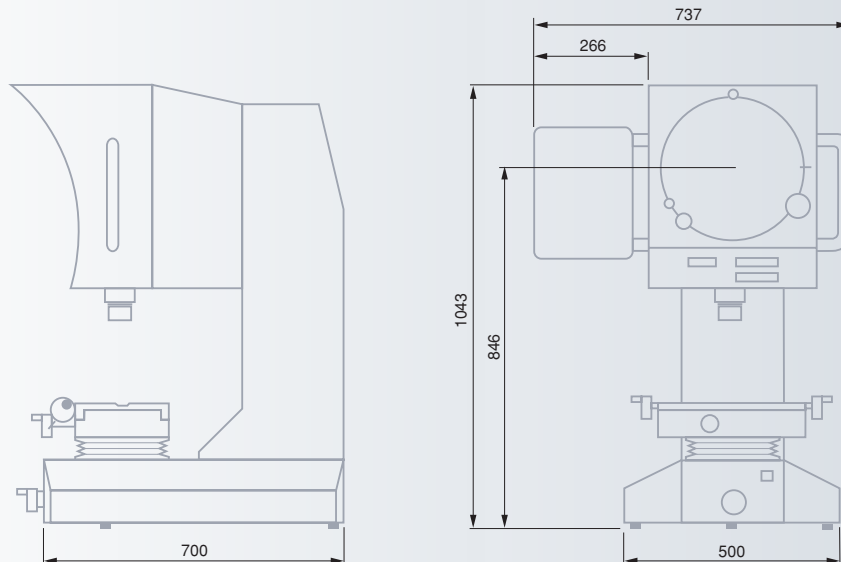
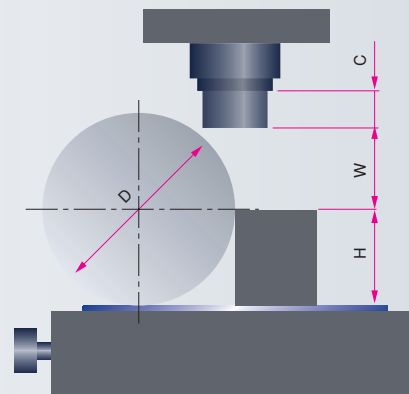

Accessories



- 06860015** 200 x 100 mm glass plate
- 06860016** 300 x 150 mm glass plate
- 06860017** 300 mm diameter viewing screen with 4 overlay chart clips
- 06860020** Profile lamp, 24 V – 150 W
- 06860021** Surface lamp, 24 V – 200 W
- 06860022** 150 mm dia. rotary table. Used with the 200 x 100 mm measuring table.
- 06860029** 150 mm dia. rotary table. Used with the 300 x 150 mm measuring table.
- 06860024** V-blocks and centres
- 06860025** Vise stage
- 06860027** TESApractice piece
- 06860060** 90 mm rotary table. Used with the 200 x 100 mm measuring table.
- 06860061** 90 mm rotary table. Used with the 300 x 150 mm measuring table.

*Rigid plastic foils, 300 mm in diameter*

- 06869055\*** Radii
- 06869056\*** Radii and angles
- 06869057\*** Thread profiles

\* See page P-29

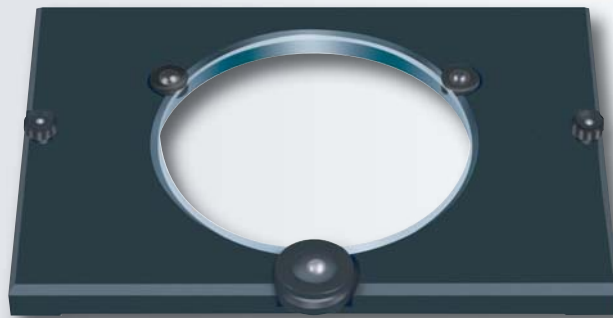

06860022/29

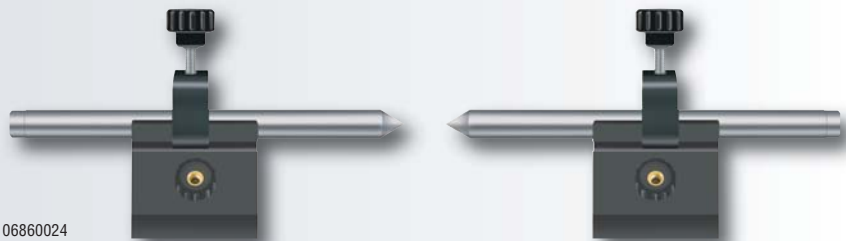

06860024



06860025

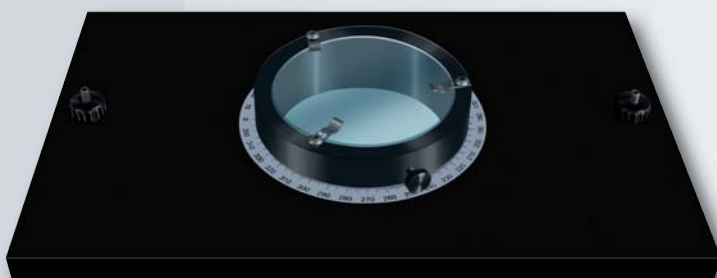

06860061



06860060







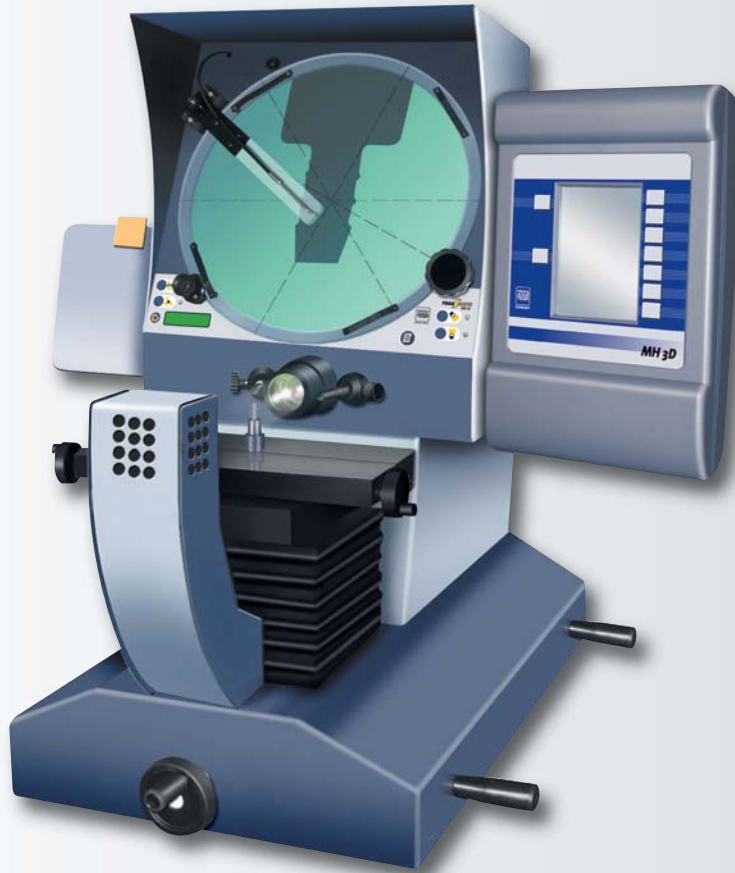













# TESA-SCOPE II 355H or 355H Plus

Designed for checking round parts.



- Profile projectors with horizontal illumination.
- 360° rotary viewing screen in frosted glass, 300 mm diameter. 30°, 60° or 90° crossline reticle along with 4 overlay chart clips.
- Screen rotation with built-in sexagesimal and decimal reading, resolution in minutes – RAZ ABS/INC.
- Profile illumination with green filter included. Enhances image contrast, makes the measurement easier, reduces all effects due to the operator.
- Surface illumination through adjustable fibre optic for a perfect image projection.
- Save Lamp system for automatic shut down of the lamps whenever the projector remains unused for several minutes (thus increasing the life of the lamps by 5).
- Objectives with bayonet mount for quick exchange.
- Coordinate table equipped with incremental glass scales, opto-electronic. Resolution to 0,001 mm.  
Measuring span:
  - 200 x 100 for the standard model
  - 300 x 100 for the model **Plus**
  - X-axis fitted with a clutch mechanism for fast displacement.
  - Control handle for left hand and right hand operator (X-axis motion).
  - Workload capacity up to 10 kg with no loss of accuracy.
- Lateral paper sheet holder.

Main Part

-  ✓
-  Heavy duty all steel structure
-  Measuring system with incremental glass scale, opto-electronic. Resolution 0,001 mm.
-  Optics precision  $\pm 0,05\%$  (profile illumination);  $\pm 0,10\%$  (surface illumination).
-  Focusing 80 mm
-  Resolution 0,001 mm
-  Profile illumination: 24 V / 150 W bulb. Also with thermal filter included. Surface illumination: adjustable fibre optic, 24 V / 200 W bulb. Also with thermal filter included.
-  10°C to 40°C
-  19°C to 21°C
-  80%, non-condensing
-  115 to 230 Vac  $\pm 10\%$ ; 50 to 60 Hz
-  110 kg
-  IP40
-  IEC 61010  
EN 60204  
EN 61326-1
-  Serial number
-  TESA calibration certificate
-  Declaration of conformity
-  Provided fully mounted, but w/o objective (must be ordered separately)
-  Shipping packaging



Small Table

- Anodized aluminium
- Table surface 350 x 100 mm (X/Y)
- Measuring span 200 x 100 mm (X/Y)
- In one coordinate direction:  $(4,5 + L/40) \mu\text{m}$   $\leq 8 \mu\text{m}$  (L in mm)
- Max. workload capacity 10 kg

Large Table

- Anodized aluminium
- Table surface 440 x 100 mm (X/Y)
- Measuring span 300 x 100 mm (X/Y)
- In one coordinate direction:  $\pm 5,0 + L/20$  (L in mm)
- Max. workload capacity 10 kg

	Base	Measuring table		Digital Readout / Control Panel		
		X=200 mm Y=100 mm	X=300 mm Y=100 mm	TS100	TS300	TS300E
<b>TESA-Scope II 355H</b> <b>06830051</b>	●	●		●		
<b>TESA-Scope II 355H</b> <b>06830052</b>	●	●			●	
<b>TESA-Scope II 355H</b> <b>06830053</b>	●	●				●
<b>TESA-Scope II 355H Plus</b> <b>06830054</b>	●		●	●		
<b>TESA-Scope II 355H Plus</b> <b>06830055</b>	●		●		●	
<b>TESA-Scope II 355H Plus</b> <b>06830056</b>	●		●			●

Telecentric Objectives

	10x	20x	25x	31,25x	50x	100x
<b>06860001</b>	<b>06860001</b>	<b>06860002</b>	<b>06860003</b>	<b>06860004</b>	<b>06860005</b>	<b>06860006</b>
Object-field	35 mm	17.5 mm	14 mm	11.2 mm	7 mm	3.5 mm
working distance (W)	80 mm	82 mm	70 mm	56 mm	53 mm	43 mm
Maximum height (H)	100 mm	100 mm	100 mm	100 mm	100 mm	100 mm
Maximum diameter (D)	200 mm	200 mm	200 mm	200 mm	200 mm	200 mm
Objective length (C)	37 mm	35 mm	47 mm	61 mm	64 mm	74 mm
Max. width of component	165 mm	165 mm	165 mm	165 mm	165 mm	165 mm
$X=Y-(W+C)$						

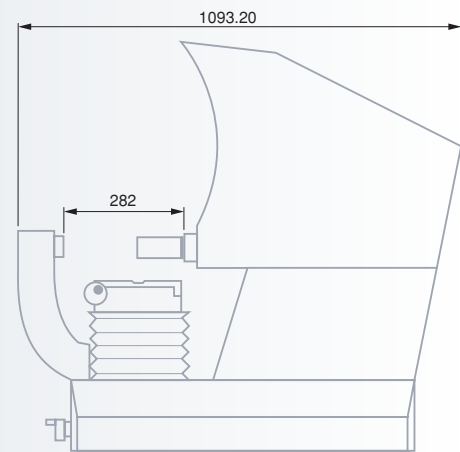
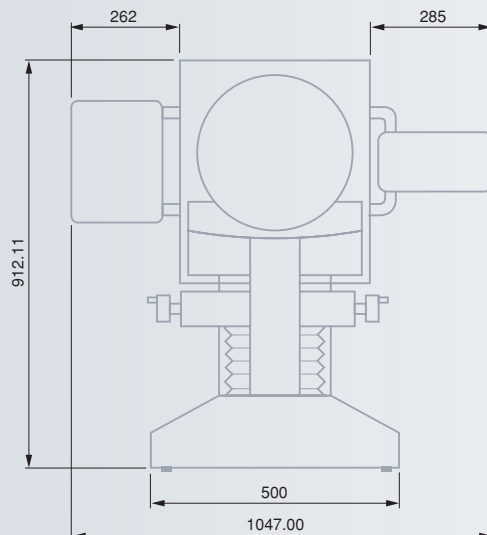
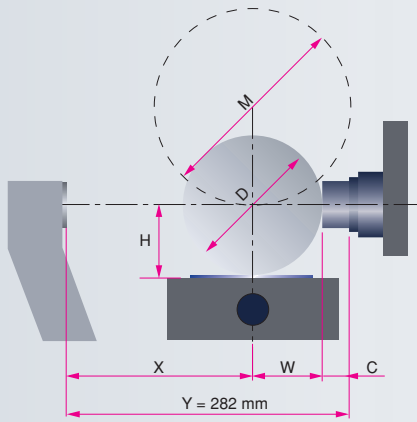

## Accessories

N°	=
06860018	355 mm dia. viewing screen with 4 overlay chart clips
06860020	Profile lamp, 24 V – 150 W
06860021	Surface lamp 24 V – 200 W
06860024	V-blocks and centres
06860025	Vise stage
06860026	Vise stage with base
06860056	Rotary table for model 355H
06860057	Prism for rotary table N° 06860056
06860058	Vise for rotary table N° 06860056
06860059	Vertical support for glass plate

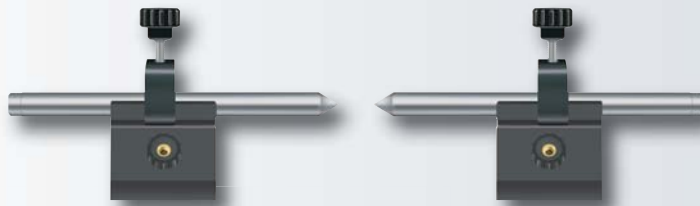

06860024



06860026 (Vise stage with base 06860025)



06860056



06860057

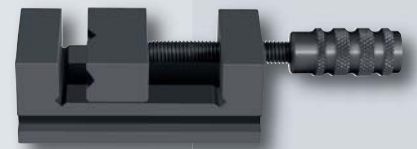

06860058



06860059



Main Part



Heavy duty all steel structure



Measuring system with incremental glass, scale, opto-electronic. Resolution 0,001 mm.



In one coordinate direction:  
(4,5 + L/40)  $\mu\text{m}$   
 $\leq 8 \mu\text{m}$  (L in mm)



Optics precision  $\pm 0,05\%$  (profile illumination);  
 $\pm 0,10\%$  (surface illumination).



Focusing 70 mm



Resolution 0,001 mm



Profile illumination: 24 V / 150 W bulb. Also with thermal filter included.  
Surface illumination: adjustable fibre optic, 24 V / 200 W bulb. Also with thermal filter included.



10°C to 40°C



19°C to 21°C



80%, non-condensing



115 to 230 Vac  $\pm 10\%$ ; 50 to 60 Hz



200 kg



IP40



IEC 61010  
EN 60204  
EN 61326-1



Serial number



TESA calibration certificate



Declaration of conformity



Provided fully mounted, but without objective (must be ordered separately)



Shipping packaging

## TESA-SCOPE II 500V

Used with overlay chart – Comes with a single objective with a 5x magnification or two objectives with magnifications from 10x up to 100x.



- Profile projector with vertical illumination.
- 360° rotary viewing screen in frosted glass, 300 mm diameter. 30°, 60° or 90° crossline reticle along with 4 overlay chart clips.
- Screen rotation with built-in sexagesimal and decimal reading, resolution in minutes – RAZ ABS/INC.
- Profile illumination with green filter included. Enhances image contrast, makes the measurement easier, reduces all effects due to the operator.
- Surface illumination through adjustable fibre optic for a perfect image.
- Save Lamp system for automatic shut down of the lamps whenever the projector remains unused for several minutes (thus increasing the life of the lamps by 5).
- Rail mounted holder for two objectives with magnifications from 10x up to 100x. Indexable linear displacement.
  - Objectives with bayonet mount.
- Coordinate table equipped with incremental glass scales, opto-electronic. Resolution to 0,001 mm.
  - 200 x 100 mm measuring span.
  - X-axis fitted with a clutch mechanism for fast displacement.
  - Control handle for left hand and right hand operator (X-axis motion).
  - Workload capacity up to 10 kg with no loss of accuracy.
- Lateral paper sheet holder.
- Protective cover with curtain for examination in bright ambient light provided as standard accessory.



		Base	Measuring Table X=200 mm Y=100 mm	Digital Readout / Control Panel		
				TS100	TS300	TS300E
TESA-Scope II 500V, 5x	06830061	●	●	●		
TESA-Scope II 500V, 5x	06830062	●	●		●	
TESA-Scope II 500V, 5x	06830063	●	●			●
Objective 5x comes along with the profile projector.						
TESA-Scope II 500V, 2 objectives*	06830064	●	●	●		
TESA-Scope II 500V, 2 objectives*	06830065	●	●		●	
TESA-Scope II 500V, 2 objectives*	06830066	●	●			●

\* Objective 5x cannot be mounted on the model that uses 2 objectives.  
Provided with 1 rail for 2 objectives with magnifications from 10x up to 100x (not included for both).

### Measuring Table

- Anodized aluminium
- Table surface 440 x 282 mm (X/Y)
- Measuring span 200 x 100 mm (X/Y)
- Max. workload capacity 10 kg

### Telecentric Objectives

	5x	10x	20x	25x	31,25x	50x	62,5x	100x
		06860008	06860009	06860010	06860011	06860012	06860013	06860014
Object-field	100 mm	50 mm	25 mm	20 mm	15,9 mm	10 mm	8 mm	5 mm
working distance (W)	220 mm	138 mm	138 mm	118 mm	90 mm	100 mm	76 mm	48 mm
Max. height (M)	100 mm	100 mm	100 mm	100 mm	100 mm	100 mm	100 mm	100 mm
Max. diameter (D)	160 mm	160 mm	160 mm	160 mm	160 mm	160 mm	160 mm	160 mm
Objective length (C)	45 mm	87 mm	82 mm	105 mm	133 mm	61 mm	85 mm	111 mm

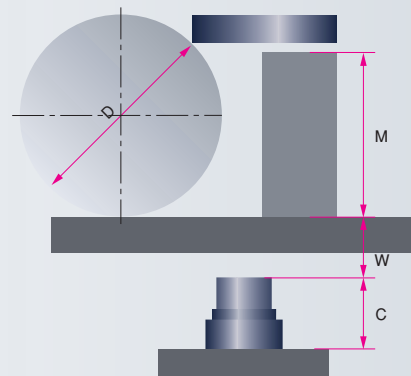

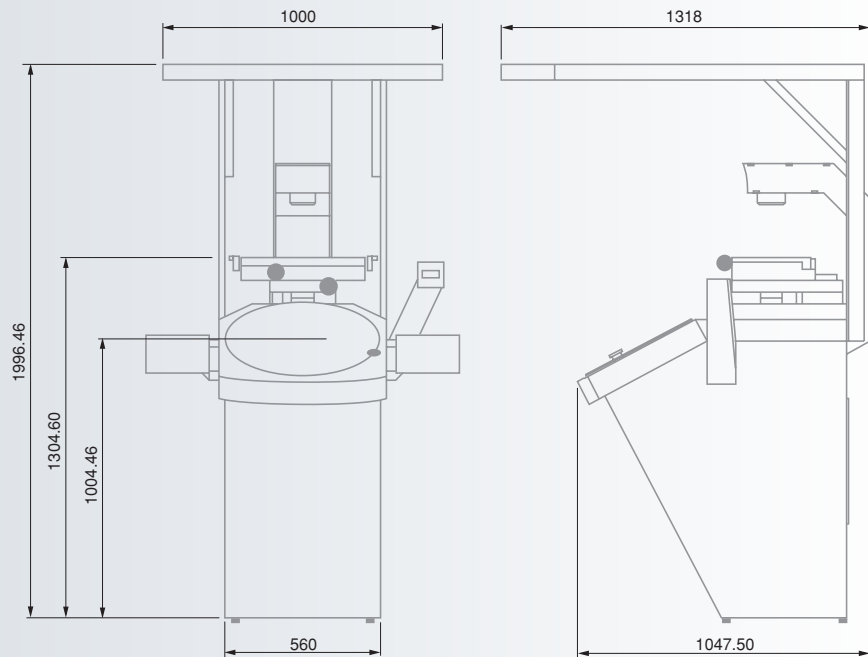

Accessories

No	
06860016	300 x 150 mm glass plate
06860019	500 mm dia. viewing screen with 4 overlay chart clips
06860020	Profile lamp, 24 V – 150 W
06860021	Surface lamp, 24 V – 200 W
06860024	V-blocks with centres
06860025	Vise stage
06860027	TESA practice piece
06860029	150 mm dia. rotary table for models 300 V Plus and 500 V
06860061	90 mm dia. rotary table. Suited for the 300 x 150 mm measuring table.

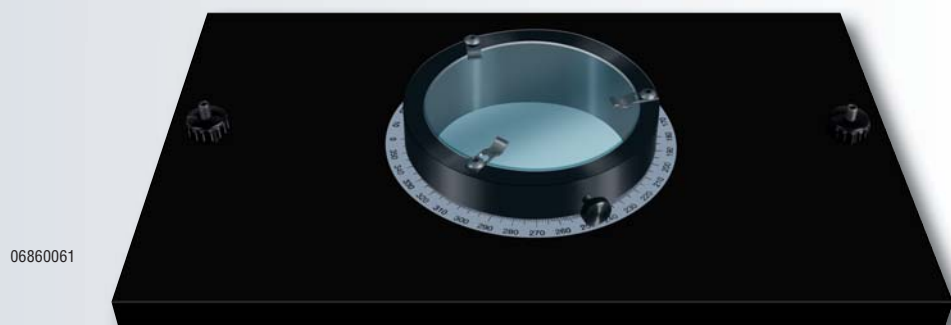
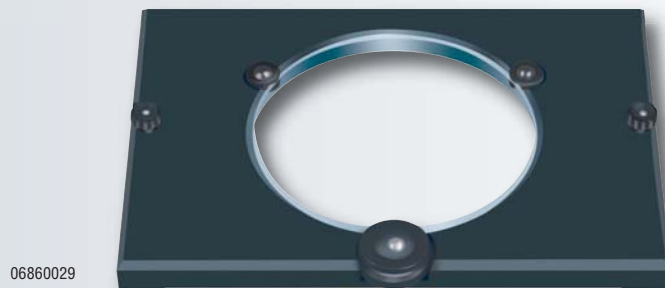
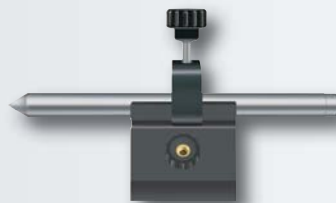
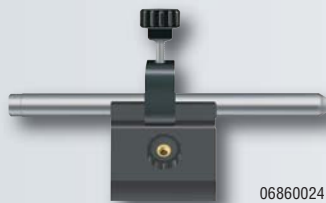

## TS-300 or TS-300E Control Panel

Each unit is able to run TESA REFLEX 2D – The Reference in terms of simplicity and reliability.

- Geometric form elements
  - Point – Line – Circle
- Measuring functions
  - Alignment – Input of reference values – Translation – Rotation
- Construction features
  - Intersection – Bolt hole circle – Line
- Result output
  - Data transfer through the RS 232 output
  - Possible conversion into DXF format
  - Statistical data processing etc.



**A** 89 x 118 mm display field with illuminated background

**000** 7-decade digit display plus sign for all measured values.

Icon-based User's guidance

RS 232

Shipping packaging

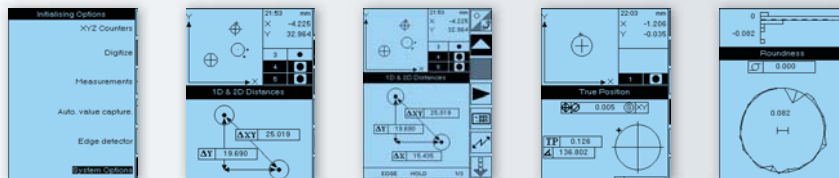

- |                 |   |
|-----------------|---|
| <b>06830031</b> | TS-100 Digital readout                    |
| <b>06830034</b> | TS-300 Control panel                      |
| <b>06830035</b> | TS-300-E Control panel with edge detector |





RS 232

Model 300V:  
integrated into  
the unit.  
Models 355H and 500V:  
single unit

Shipping  
packaging

## TS-100 Digital Readout

- Numerical display (X/Y axes)
- Resolution to 0,001 mm
- Inch/metric conversion
- Separate zeroing of display in both X/Y-axes
- ABS/INC measuring mode
- Linear correction of scaling errors (X/Y axes)
- Control option for both profile and surface illumination
- RS 232 digital output (SPC Printer)

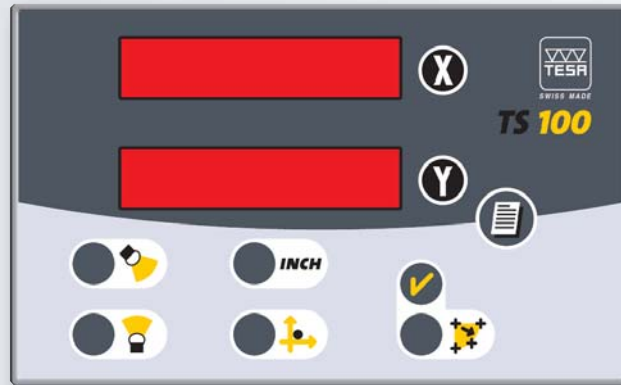

### Measuring functions

- **Diameter** 3 to 10 data points
- **Radius** 3 to 10 data points
- **Centre distance** Centre-to-centre distance of the last measured feature (radius or diameter)
- **Auto Enter** Automatic value acquisition



### Accessories for Profile Projectors

**No**



- 06860035** Calibration standard for diameter and magnification
- 06860036** Angle support for calibration standard (model 355H)

### Measuring Foils

**No**



- 06869055** Type RA for measuring radius, circle, bending radius. Convenient for model 300 V.
  - 06869056** Type PO for measuring radius or angle. Suited for model 300 V.
  - 06869057** Type M2 ISO for measuring thread profile. Suited for model 300 V.
- Other types and sizes for models 355H and 500V available on request.

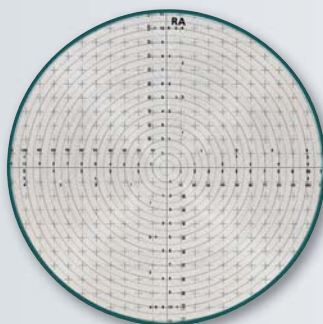

06869055

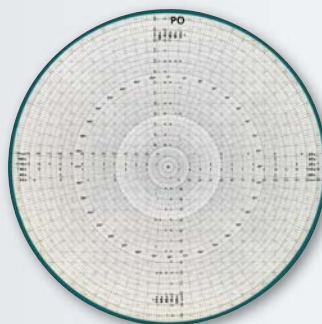

06869056

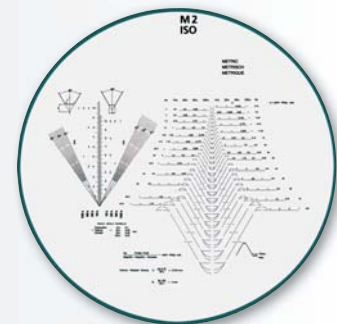

06869057



## Brown & Sharpe V-Blocks and Clamps

V-Blocks have a frame for clamping cylindrical parts with diameters ranging from 0,7 to 40 mm– Used for workpiece inspection or machining.



Hardened steel



Ground resting faces and vee faces



Not available as single items



Suited plastic case

**No**



Clamping range  
mm

<b>06769007</b>	Set of Brown & Sharpe V-blocks	0,7 ÷ 40
<i>Supplied with:</i>		
	1 Pair of V-blocks	5 ÷ 40
	1 Extra V-block	3 ÷ 8
	1 Extra V-block	1,5 ÷ 5
	5 Extra V-blocks	0,7 ÷ 3,5
	2 In-between bridges	
	2 Large frames	
	1 Small frame	

