

# TESA Axial Probes

## Standard and LVDT Probes

Universal probes for common but constraining applications.

- 8 mm diameter probe housing. Can be clamped over its entire length.
- Measuring bolt mounted on a ball bearing.
- Both the probe housing and ball-bearing guide are separate from one another, so that the measuring bolt moves easily even if the probe is not clamped appropriately.
- Degree of protection IP65 according to IEC 60529.
- Wide range of accessories including measuring inserts, spring sets, etc.
- Compatible with measuring equipment from other makers (see page N-14).



DIN 32876 Part 1

See in the table

Axial probes usable in any position

8 mm dia. fixing shank. Ball-bearing measuring bolt.

Distance from electrical zero of both stops is either adjustable (downward) or depending on the position of the lower stop (upward).

Interchangeable measuring insert with a 3 mm dia. tungsten carbide ball tip plus M2,5 thread.

2 m long cable. DIN 45322 5-pin connector, LVDT probes not included.

Nickel-plated housing. Stainless steel measuring bolt, hardened.

Sealing bellows made from resistant Nitrile or high-resistance Viton (elastomer)

Moved mass 6 g

13 kHz (± 5%) drive frequency.

For LVDT probes, see on pages N-12 and N-13. Highest mechanical frequency to 60 Hz.

0,15 µm/°C or 0,2 µm/°C for GTL 21 and GTL 211

20 ± 0,5°C

-10°C to 65°C  
10°C to 40°C for GT 21 HP

80%

IP65 (IEC 60529), IP64 for GT 21 HP

Shipping packaging

Identification number

Inspection report with a declaration of conformity

### GT 21 and GTL 21 probes with axial cable exit

		Measuring range (mm)	N*	Measuring bolt retraction	Sealing bellows
<i>Standard probes</i>					
<b>03210904</b>	<b>GT 21</b>	± 2	0,63	mechanical	Nitrile
<b>03210905</b>	<b>GT 21</b>	± 2	1,0	mechanical	Nitrile
<b>03210906</b>	<b>GT 21</b>	± 2	1,6	mechanical	Nitrile
<b>03210907</b>	<b>GT 21</b>	± 2	2,5	mechanical	Nitrile
<b>03210908</b>	<b>GT 21</b>	± 2	4,0	mechanical	Nitrile
<b>03230057</b>	<b>GTL 21</b>	± 2	0,63	mechanical	Nitrile
<b>03230072</b>	<b>GTL 211</b>	± 2	0,63	vacuum	Viton
<i>High-precision standard probes</i>					
<b>03230036</b>	<b>GT 21 HP</b>	± 0,2	0,63	mechanical	nitrile
<i>LVDT-probes</i>					
<b>03230029</b>	<b>GT 21 LVDT</b>	± 1,5	0,63	mechanical	nitrile

\* Nominal value at electrical zero, max. ± 25%. Valid for upright assembly position, with downward oriented measuring bolt, as well as in static measuring.

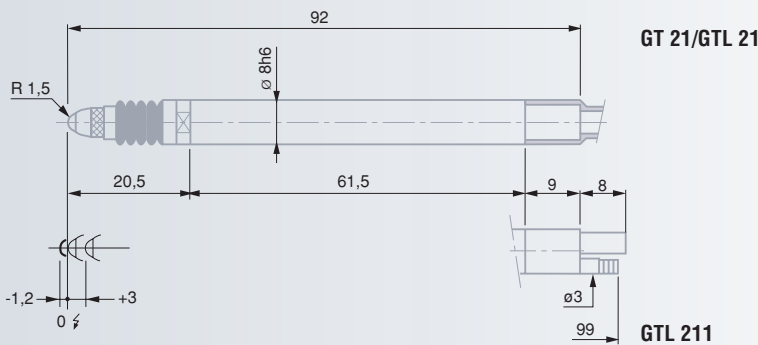

	mm	µm	µm	µm***	Technical data sheets
<b>GT 21</b>	-2,2 to 0,1	-1,2 to 4,3	0,01 to 0,02	0,2 + 3 · L <sup>3</sup>	03200249
<b>GTL 21</b>	-2,2 to 0,1	-1,2 to 4,3	0,01 to 0,02	0,2 + 2,4 · L <sup>2</sup>	03200391
<b>GTL 211</b>	-2,2 to 0,1	-1,2 to 4,3	0,01 to 0,02	0,2 + 2,4 · L <sup>2</sup>	03200435
<b>GT 21 HP</b>	-2,2 to 0,1	-1,2 to 4,3	0,01 to 0,01	0,07 + 0,4 · L	03200264
<b>GT 21 LVDT</b>	-2,2 to 0,1	-1,7 to 4,3	0,15 to 0,15	4,5****	03200228

\*\* Distance from electrical zero. \*\*\* Linearity related max. perm. errors (L in mm).  
\*\*\*\* With reference to the 3 mm measuring span (measuring range ±1,5 mm)



## GT 22 and GTL 22 probes with radial cable exit

		Measuring range (mm)	N*	Measuring bolt retraction	Sealing bellows
<i>Standard probes</i>					
03210924	GT 22	± 2	0,63	vacuum	Nitrile
03210921	GT 22	± 2	0,16	vacuum	Nitrile
03210922	GT 22	± 2	0,25	vacuum	Nitrile
03210923	GT 22	± 2	0,4	vacuum	Nitrile
03210925	GT 22	± 2	1,0	mechanical	Nitrile
03210926	GT 22	± 2	1,6	mechanical	Nitrile
03210927	GT 22	± 2	2,5	mechanical	Nitrile
03210928	GT 22	± 2	4,0	mechanical	Nitrile
03230056	GTL 22	± 2	0,63	vacuum	Viton
03230076	GTL 22	± 2	1	vacuum	Viton
<i>High-precision standard probes</i>					
03230021	GT 22 HP	± 0,2	0,63	vacuum	Nitrile
<i>LVDT probes</i>					
03230030	GT 22 LVDT	± 1,5	0,63	mechanical	Nitrile

\* Nominal value at electrical zero, max. ± 25%. Valid for upright assembly position, with downward oriented measuring bolt, as well as in static measuring.



GT 22/GTL 22

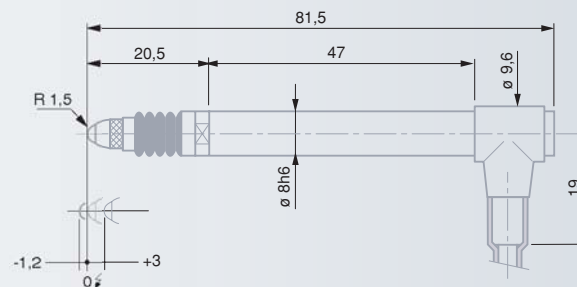

Lower stop of the measuring bolt**, adjustable from... to ex-factory	mm	µm	µm	µm***		Technical data sheets		
GT 22	-2,2	0,1	-1,2	4,3	0,01	0,02	0,2 + 3 · L <sup>3</sup>	03200250
GTL 22	-2,2	0,1	-1,2	4,3	0,01	0,02	0,2 + 2,4 · L <sup>2</sup>	03200392
GT 22 HP	-2,2	0,1	-1,2	4,3	0,01	0,01	0,07 + 0,4 · L	03200265
GT 22 LVDT	-2,2	0,1	-1,7	4,3	0,15	0,15	4,5****	03200229

\*\* Distance from electrical zero. \*\*\* Linearity related max. perm. errors. (L in mm).  
\*\*\*\* With reference to the 3 mm measuring span (measuring range ±1,5 mm).



DIN 32876 Part 1



See in the table



Axial probes usable in any position



8 mm dia. fixing shank. Ball-bearing measuring bolt.

Distance from electrical zero of both stops is either adjustable (downward) or depending on the position of the lower stop (upward).

Interchangeable measuring insert with a 3 mm dia. tungsten carbide ball tip plus M2,5 thread.

2 m long cable. DIN 45322 5-pin connector, LVDT probes not included.



Nickel-plated housing. Stainless steel measuring bolt, hardened.

Sealing bellows made from resistant Nitrile or high-resistance Viton (elastomer)



Moved mass 6 g



13 kHz (± 5%) drive frequency.

For LVDT probes, see on pages N-12 and N-13.

Highest mechanical frequency to 60 Hz.

0,15 µm/°C or 0,2 µm/°C for GTL 22



20 ± 0,5°C



-10°C to 65°C  
10°C to 40°C for GT 22 HP



80%



IP65 (IEC 60529) or IP64 for GT 22 HP



Shipping packaging



Identification number



Inspection report with a declaration of conformity



DIN 32876 Part 1

See in the tables

Axial probes usable in any position

8 mm dia. fixing shank. Ball-bearing measuring bolt.

Distance from electrical zero of both stops is either adjustable (downward) or depending on the position of the lower stop (upward).

Interchangeable measuring insert with a 3 mm dia. tungsten carbide ball tip plus M2,5 thread.

2 m long cable. Standard probes with a 5-pin DIN 45322 connector. LVDT probes have no connector.

Nickel-plated housing. Stainless steel measuring bolt, hardened.

Viton rubber bellow in high-resistance elastomer

Moving mass 8 g

13 kHz (± 5%) drive frequency.

For LVDT probes, see on pages N-12 and N-13.

Highest mechanical frequency to 60 Hz.

0,15 µm/ °C

20 ± 0,5 °C

-10°C to 65°C

80%

IP65 (IEC 60529)

Shipping packaging

Identification number

Inspection report with a declaration of conformity

# TESA Axial Probes with Long Retraction Travel

## Standard and LVDT Probes

Universal inductive probes for common applications, especially those using multigauging devices.

- Long retraction travel to prevent the probe from being damaged.
- Compatible with measuring equipment from other makers (see page N-14).

### GT 27 probes with axial cable exit

			Measuring range (mm)	N*	Measuring bolt retraction	Sealing bellows
<i>Standard probes</i>						
<b>03230027</b>	<b>GT 27</b>		± 2	0,63	mechanical	Viton
<b>03230073</b>	<b>GT 271</b>		± 2	0,63	vacuum	Viton
<i>LVDT probe</i>						
<b>03230031</b>	<b>GT 27 LVDT</b>		± 1,5	0,63	mechanical	Viton

### GT 28 probes with radial cable exit

			Measuring range (mm)	N*	Measuring bolt retraction	Sealing bellows
<i>Standard probes</i>						
<b>03230026</b>	<b>GT 28</b>		± 2	0,63	vacuum	Viton
<i>LVDT probe</i>						
<b>03230032</b>	<b>GT 28 LVDT</b>		± 1,5	0,63	by vacuum	Viton

\* Nominal value at electrical zero, max. ±25%. Valid for upright assembly position, with downward oriented measuring bolt, as well as in static measuring.

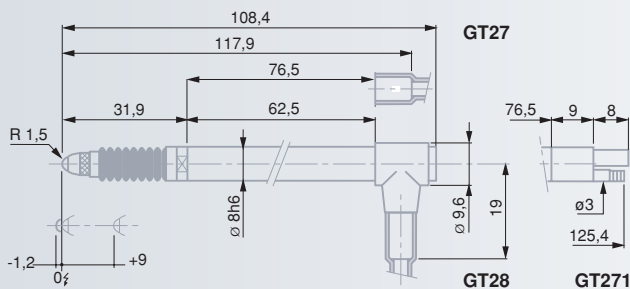

	Lower stop of the measuring bolt**, adjustable from... to	mm	mm	mm	µm	µm	µm***	Technical data sheets
<b>GT 27</b>	-2,2	0,1	-1,2	10,3	0,05	0,05	0,2 + 3 · L <sup>3</sup>	03200251
<b>GT 271</b>	-2,2	0,1	-1,2	10,3	0,05	0,05	0,2 + 3 · L <sup>3</sup>	03200436
<b>GT 28</b>	-2,2	0,1	-1,2	10,3	0,05	0,05	0,2 + 3 · L <sup>3</sup>	03200252
<b>GT 27 LVDT</b>	-2,2	0,1	-1,7	10,3	0,15	0,15	4,5****	03200245
<b>GT 28 LVDT</b>	-2,2	0,1	-1,7	10,3	0,15	0,15	4,5****	03200246

\*\* Distance from electrical zero. \*\*\* Linearity related max. perm. errors (L in mm).  
\*\*\*\* With reference to the 3 mm measuring span (measuring range ±1,5 mm).



# TESA Axial Probes with Extended Measuring Range

## Standard and LVDT Probes

Designed for long travels and low resolutions – Specially suited for use with multigauging systems.

- Correction factor used to get the true value is 2,5x (10x for the S probe version).

Compatible with measuring equipment from other makers (see page N-14).

### GT 61 probes with axial cable exit

		Measuring range (mm)	N*	Measuring bolt retraction	Sealing bellows		
<i>Standard probes</i>							
03230041	GT 61	± 5	0,9	mechanical	Viton		
S32070041	GT 61S	± 5	0,9	mechanical	Viton		
03230074	GT 611	± 5	0,9	vacuum	Viton		
<i>LVDT probes</i>							
03230046	GT 61 LVDT	± 5	0,9	mechanical	Viton		

### GT 62 probes with radial cable exit

		Measuring range (mm)	N*	Measuring bolt retraction	Sealing bellows		
<i>Standard probes</i>							
03230042	GT 62	± 5	0,9	vacuum	Viton		
S32070042	GT 62S	± 5	0,9	vacuum	Viton		
S32080861	GT62	± 5	0,16	mechanical	none		
<i>LVDT probes</i>							
03230048	GT 62 LVDT	± 5	0,9	vacuum	Viton		

\* Nominal value at electrical zero, max. ± 25%. Valid for upright assembly position, with downward oriented measuring bolt, as well as in static measuring.



GT 62

GT 61

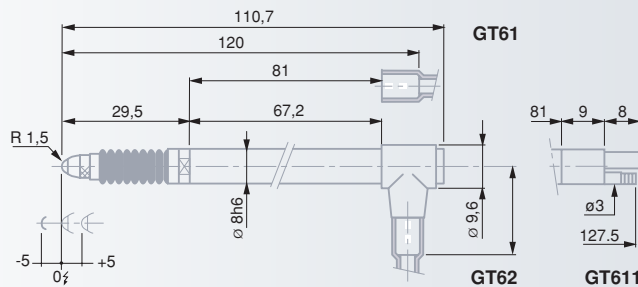

	Measuring bolt stops**	mm	lower stop (mm)	upper stop (mm)	mm	µm	µm	Technical data sheets
GT 61			-5,1	5,2	10,3	0,05	0,05	1 + 4 · L
GT 611			-5,1	5,2	10,3	0,05	0,05	1 + 4 · L
GT 62			-5,1	5,2	10,3	0,05	0,05	1 + 4 · L
GT 61 LVDT			-5,1	5,2	10,3	0,2	0,2	20****
GT 62 LVDT			-5,1	5,2	10,3	0,2	0,2	20****

\*\* Distance from electrical zero. \*\*\* Linearity related max. perm. errors (L in mm).  
\*\*\*\* With reference to the 10 mm measuring span (measuring range ±5 mm).

- ✓
- DIN 32876 Part 1
- See in the tables
- Axial probes usable in any position
- Signal combination with probes having a standard resolution may require your special attention to needed correction
- 8 mm dia. fixing shank. Ball-bearing measuring bolt
- Both lower and upper stops are fixed.
- Interchangeable measuring insert with a 3 mm dia. tungsten carbide ball tip. M2,5 thread.
- 2 m long cable.
- 5-pin DIN 45322 connector, LVDT probes not included.
- Nickel-plated housing. Stainless steel measuring bolt, hardened.
- Viton rubber bellows in high-resistance elastomer
- Moved mass 8 g
- 13 kHz (± 5%) drive frequency.
- For LVDT probes, see on pages N-12 and N-13.
- Highest mechanical frequency to 60 Hz.
- 0,09 µm/°C or 0,16 µm/°C for GT 61 and GT 62 LVDT probes
- 20 ± 0,5°C
- 10°C to 65°C
- 80%
- IP65 (IEC 60529)
- Shipping packaging
- Identification number
- Inspection report with a declaration of conformity



DIN 32876 Part 1

See in tables

Axial probes usable in any position

8 mm body diameter. Measuring bolt mounted on a ball-bearing.

Adjustable distance between both lower stop and electrical zero.

Interchangeable measuring insert with M2,5 thread. 3 mm dia. carbide ball tip.

Cable length: 2 m.

DIN 45322 connector.

Nickel-plated body. Steel measuring bolt, hardened.

Viton rubber bellow with high-resistance elastomer

Moved mass 6 g

Force increase 0,2 N/mm

Highest mechanical frequency 60 Hz

0,2  $\mu\text{m}/^\circ\text{C}$

-10°C to 65°C

-20°C to 65°C

IP65 (IEC 60529)

Shipping packaging

Identification number

## TESA Axial Probes – Series 490 and 491

Probes with no brand name for use with both TESA and MERCER electronic equipment

Universal probes to suit common but constraining applications.

- 8 mm diameter probe body that can be clamped over its entire length.
- Measuring bolt mounted on a ball-bearing.
- Probe body made in steel, nickel-plated.
- Degree of protection to IP65 as per IEC 60529.
- Probe series 490 provided with a flexible axial cable exit with steel spring to prevent the cable from breaking.

Compatible with measuring equipment from other makers (see page N-14).

Measuring range (mm)	N*	Measuring bolt retraction	Sealing bellows
----------------------	----	---------------------------	-----------------

Probe series 490 with axial/radial cable exit\*\*

03230490	03236490	± 1,5	0,63	mechanical	Viton
----------	----------	-------	------	------------	-------

Probe series 491 with radial cable exit

03230491	03236491	± 1,5	0,63	vacuum	Viton
----------	----------	-------	------	--------	-------

\* Nominal value at electrical zero; max. deviation  $\pm 0,15$  N. Valid for upright assembly position with downward oriented measuring bolt, as well as in static measuring.

Probes with measuring force of 0,4, 1,0, 1,6, 2,5 or 4 N also available upon request.

\*\* Using the right angle adaptor that came with the probe.

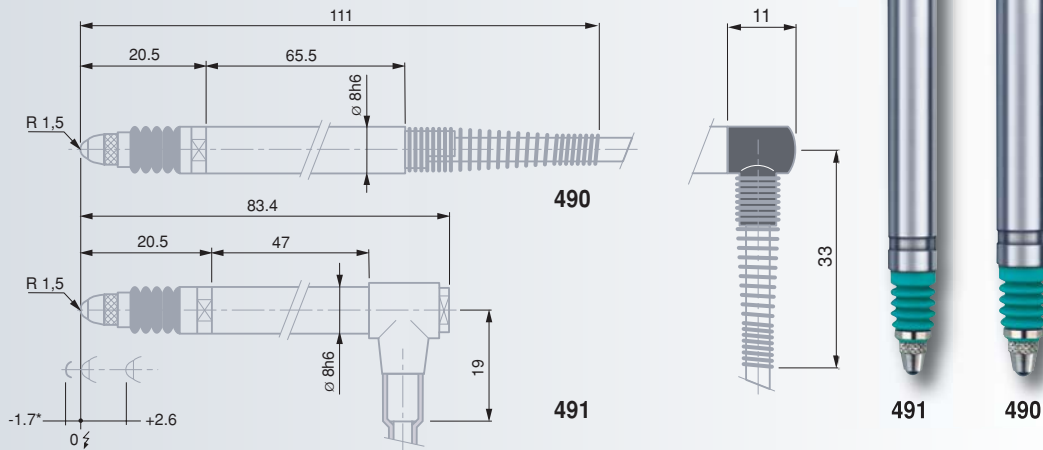

		Lower stop of the measuring bolt***, adjustable from... to... ex-factory	mm	$\mu\text{m}$	%****	Technical data sheets
490	TESA	-2 0	-1,7	4,3	0,2	03200456
490	MERCER	-2 0	-1,7	4,3	0,15	03200450
491	TESA	-2 0	-1,7	4,3	0,2	03200457
491	MERCER	-2 0	-1,7	4,3	0,15	03200454

\*\*\* Distance from electrical zero.

\*\*\*\* Linearity related max. perm. errors within the measuring span of 3 mm (measuring range  $\pm 1,5$  mm).

