



DIN 32876 Part 1

See in tables

Probes with linear action usable in any position

4 coupling threads M6. Linear

ball-bearing guiding with fixed stops.

Insert holder attachment with dovetail.

Cable length: 2 m.

Standard and FMS protected probes including aligning elements for the signals are fitted with a 5-pin DIN 45322 connector.

LVDT probes have no connector and no aligning elements.

Hardened steel probe body, nickel-plated

Moved mass 110 g

13 kHz (± 5%) drive frequency.

LVDT probes only:
3 V drive voltage
5 kHz drive frequency
100 kΩ adjustment load

Sensitivity to 150 mV/mm

Highest mechanical frequency to 25 Hz

-0,14 μm/°C or 0,15 μm/°C for LVDT probes

20 ± 0,5°C

-10°C to 65°C

80%

IP50 or IP54 for protected probes as per IEC 60529

Shipping packaging

Identification number

Inspection report with a declaration of conformity

TESA Probes with Parallel Guiding

Standard, FMS protected and LVDT probes

Universal probes for multigauging devices. Let you capture the values measured on machines or other fixtures for in-process inspection.

- Long-life probes featuring a small-size, rugged design.
- Modular construction to eliminate the need for many assembly components.
- Ball-bearing probe displacement.
- Direction of the probing force and probe retraction matching used accessory.
- Wide choice of measuring inserts and supports for optimum adaptation to your measuring job.

Compatible with measuring equipment from other makers (see page N-14).

FMS probes with parallel cable exit

No	=	Measuring range (mm)	N*	Measuring bolt retraction (accessory)
<i>Standard probes</i>				
03230019	FMS 100	± 2	2	air pressure
03230049	FMS 130	± 2,9	2	air pressure
<i>Probes «FMS protected»</i>				
03230037	FMS 100-P	± 2	2	air pressure
03230051	FMS 130-P	± 2,9	2	air pressure
<i>LVDT probes</i>				
03230033	FMS 100 LVDT	± 1,5	2	air pressure
03230039	FMS 100-P LVDT	± 1,5	2	air pressure

* Nominal value at electrical zero; max. deviation ± 25%. Valid for probing movement exerted horizontally or in static measuring.

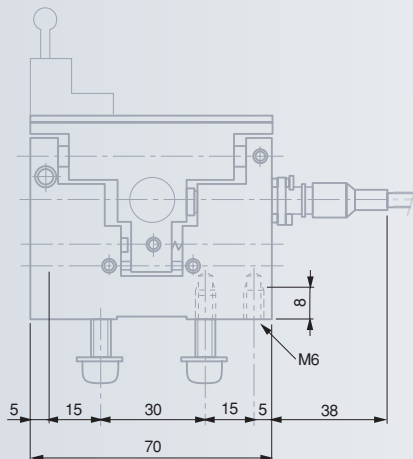

	Mechanical stop**	mm	μm	μm	μm***	Technical data sheets	
	lower mm	upper mm					
FMS 100	-2,9	2,9	5,8	0,5	0,5	0,2 + 3 · L ³	03200253
FMS 100-P	-2,9	2,9	5,8	0,5	0,5	0,2 + 3 · L ³	03200283
FMS 130	-2,9	2,9	5,8	0,5	0,5	0,2 + 3 · L ³	03200342
FMS 130-P	-2,9	2,9	5,8	0,5	0,5	0,2 + 3 · L ³	03200344
FMS 100 LVDT	-2,9	2,9	5,8	0,5	0,5	4,5****	03200247
FMS 100-P LVDT	-2,9	2,9	5,8	0,5	0,5	4,5****	03200290

** Distance from electrical zero. *** Linearity related max. perm. errors (L in mm).

**** With reference to the measuring span of 3 mm (measuring range ±1,5 mm).



FMS probes with angled cable exit



		 Measuring range (mm)	 N*	 Measuring bolt retraction (accessory)
<i>Standard probes</i>				
03230028	FMS 102	± 2	2	air pressure
03230050	FMS 132	± 2,9	2	air pressure
<i>Probes «FMS protected»</i>				
03230038	FMS 102-P	± 2	2	air pressure
03230052	FMS 132-P	± 2,9	2	air pressure
<i>LVDT probes</i>				
03230034	FMS 102 LVDT	± 1,5	2	air pressure
03230040	FMS 102-P LVDT	± 1,5	2	air pressure

* Nominal value at electrical zero; max. deviation ± 25%. Valid for probing movement exerted horizontally or in static measuring.

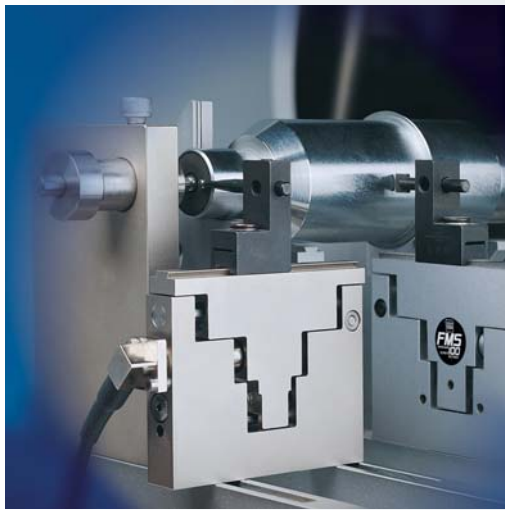

- ✓
- DIN 32876 Part 1
- See in the tables
- Probes with linear action usable in any position
- 4 coupling threads M6. Linear ball-bearing guiding with fixed stops.

Insert holder attachment with dovetail.
Cable length: 2 m.
Standard and FMS protected probes including aligning elements for the signals are fitted with a 5-pin DIN 45322 connector.

LVDT probes have no connector and no aligning elements.

- Hardened steel probe body, nickel-plated
- Moved mass 110 g
- 13 kHz (± 5%) drive frequency.

LVDT probes only:
3 V drive voltage
5 kHz drive frequency
100 kΩ adjustment load

Sensitivity to 150 mV/V/mm
Highest mechanical frequency to 25 Hz

- 0,15 μm/°C
- 20 ± 0,5°C
- 10°C to 65°C
- 80%
- IP50 or IP54 for FMS protected probes as per IEC 60529

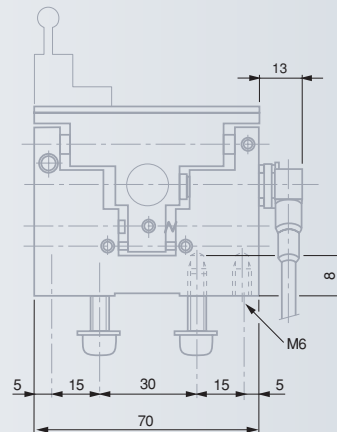

			 mm	 μm	 μm	 μm***	 Technical data sheets
	lower mm	upper mm					
FMS 102	-2,9	2,9	5,8	0,5	0,5	0,2 + 3 · L ³	03200254
FMS 102-P	-2,9	2,9	5,8	0,5	0,5	0,2 + 3 · L ³	03200289
FMS 132	-2,9	2,9	5,8	0,5	0,5	0,2 + 3 · L ³	03200343
FMS 132-P	-2,9	2,9	5,8	0,5	0,5	0,2 + 3 · L ³	03200345
FMS 102 LVDT	-2,9	2,9	5,8	0,5	0,5	4,5****	03200248
FMS 102-P LVDT	-2,9	2,9	5,8	0,5	0,5	4,5****	03200291

** Distance from electrical zero. *** Linearity related max. perm. errors (L in mm).
**** With reference to the measuring span of 3 mm (measuring range ±1,5 mm).

- Shipping packaging
- Identification number
- Inspection report with a declaration of conformity

Configuration and Use of TESA FMS Probes

The following examples provide you with a number of possibilities to activate and retract the measuring insert during your measurement cycles.

Example A

- Moving the probe insert toward the part to be inspected using the measuring force produced through the compression spring.
- No insert's retraction.

Effect

The insert remains into position. Exchanging parts is made with mechanical contact of the probe under the measuring force.

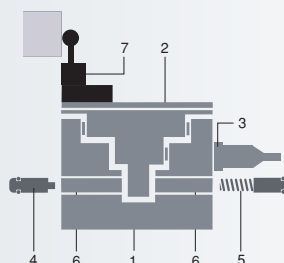

- 1 Fixed probe body
- 2 Moving probe body
- 3 Measuring element with fine adjust
- 4 Adjustable stop
- 5 Spring set for the measuring force
- 6 Mounting bores
- 7 Holder for the probe insert

Example B

- Moving the probe insert toward the part to be inspected using the measuring force produced through the compression spring.
- Insert's retraction by pneumatic pressure.

Effect

Exchanging parts is made with no mechanical contact of the probe.

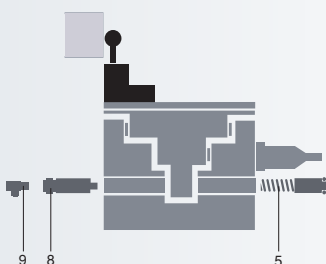

- 5 Spring set for the measuring force
- 8 Pneumatic jack, No. 03260440
- 9 Connector (No. 024388, page N-45)

Example C

- Activating the measuring insert towards the part to be inspected by air pressure using the measuring force produced by the compression spring.
- Insert's retraction by disabling the pneumatic pressure.

Effect

Exchanging parts is made with no mechanical contact of the probe, thus providing absolute security since the probe insert retract itself due to a lack of air pressure.

This configuration is also applied where there is no room on the left side for the pneumatic jack (as shown in the example B).

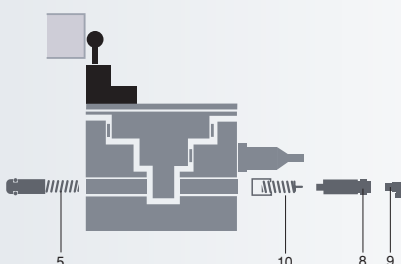

- 5 Spring set for the measuring force
- 8 Pneumatic jack, No. 03260440
- 9 Connector (No. 024388, page N-45)
- 10 Auxiliary spring-loaded element, No. 03260445



The force of the spring set (5) must be equivalent to the force of the auxiliary spring-loaded element (10).



Accessories for TESA FMS Probes

Spring set for the measuring force

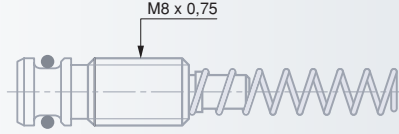

Spring set for the measuring force

Examples A to C
Item 5

	N	
*	2,0	nickel-plated
03260448	0,4	red
03260449	0,63	yellow
03260450	1,0	green
03260451	1,6	blue
03260452	2,5	brown
03260453	4,0	black

* Provided with FMS probes



All values given in the table for the measuring force equal nominal values at electrical zero; max. deviation $\pm 25\%$. Valid for probing movements exerted horizontally as well as in static measuring.



Shipping packaging

Accessories for Pneumatic Activation of the Moving Probe Body



03260440

Pneumatic jack

Operates the moving probe body. Force under a pressure of 4 bars = 11 N

Examples B and C
Item 8

Auxiliary spring-loaded element

Example C
Item 10



N

03260441	0,4	red
03260442	0,63	yellow
03260443	1,0	green
03260444	1,6	blue
03260445	2,0	nickel-plated
03260446	2,5	brown
03260447	4,0	black

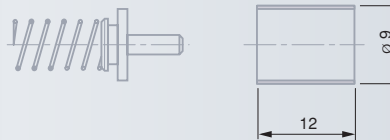
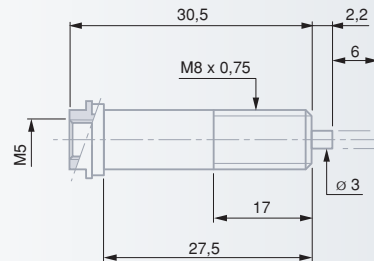

Probe Insert Holder with Fine Adjustment

Helps you to set the probe – Setting and locking screws remain accessible even when several probes are mounted side by side.



Width of the insert holder. 12 mm



Shipping packaging

Mounting bores for probe inserts



	mm	Number	Position	mm
02630053	4	2	horizontal	25
02630055	4	1	vertical	25
02630052	6	2	horizontal	25
02630054	6	1	vertical	25

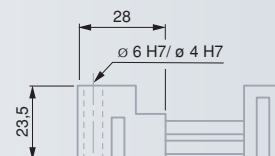
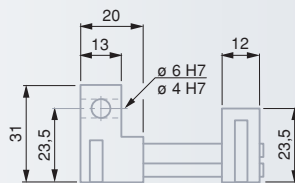
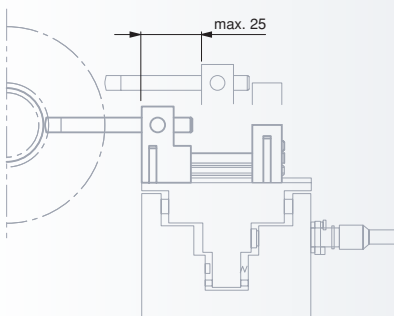

02630052/53

02630054/55

